

# CITY OF SALEM, MASSACHUSETTS

## HIGHLAND AVENUE WATER LINING PROJECT NOVEMBER 2020

IFB NO. 21-19-230

PROJECT LOCATION

CITY OF SALEM  
KIMBERLEY DRISCOLL  
Mayor

DAVID KNOWLTON, P.E.  
City Engineer

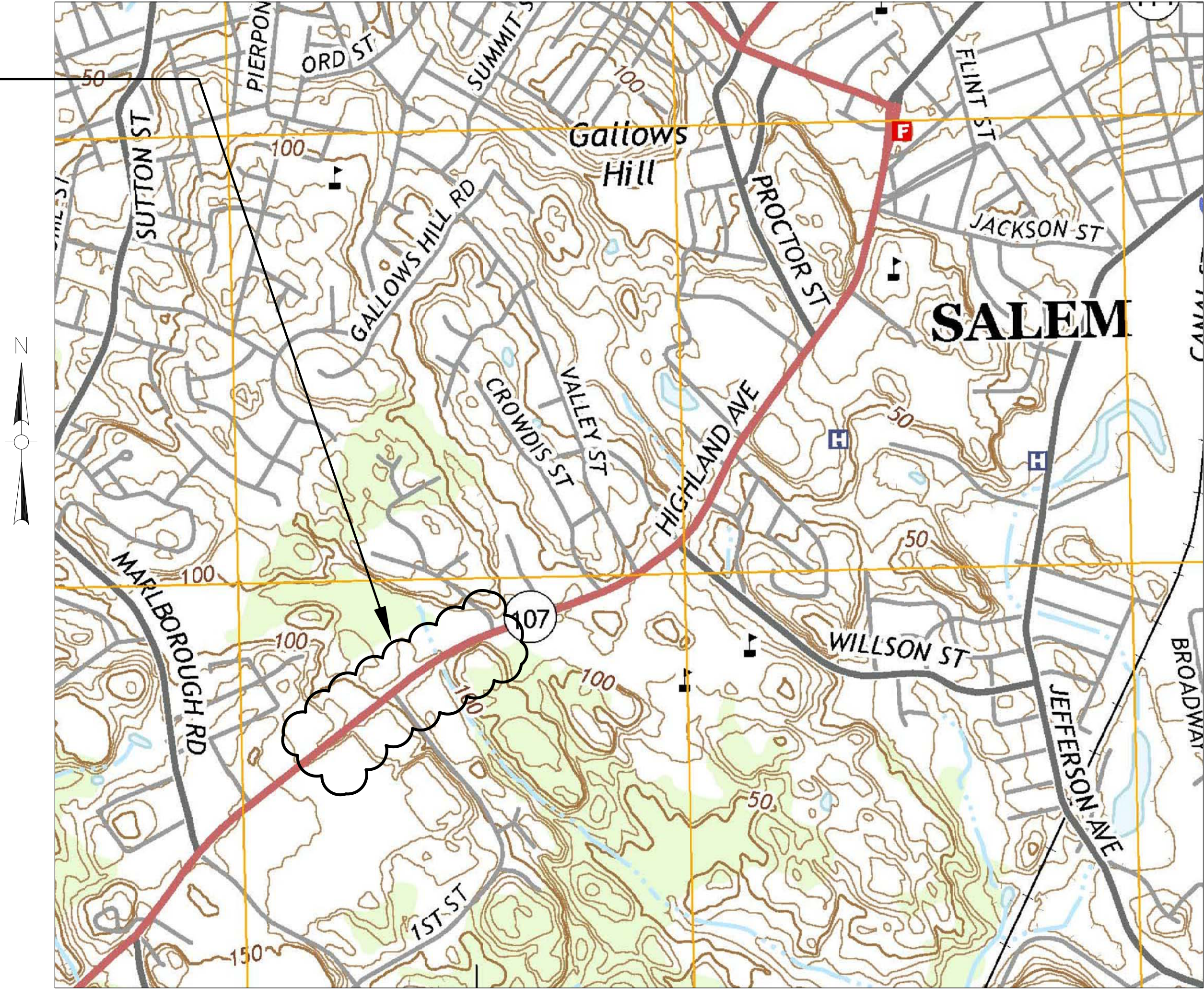

LOCUS MAP (NO SCALE)

**DRAWING INDEX:**

- G-1 COVER SHEET
- G-2 GENERAL NOTES AND LEGEND
- C-1 to C-2 UTILITY PLANS
- D-1 to D-3 DETAILS

### NEW ENGLAND CIVIL ENGINEERING CORP.



265 Essex Street  
Suite #102  
Salem, MA 01970  
  
(978) 741-7401



















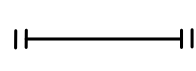
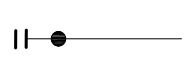

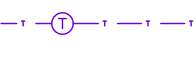
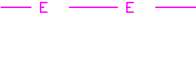



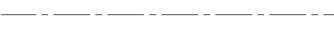

Sheet

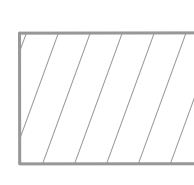

G-1

**GENERAL NOTES**

- VERTICAL DATUM BASED ON THE NORTH AMERICAN VERTICAL DATUM OF 1988 (NAVD88), HORIZONTAL DATUM BASED ON THE MASSACHUSETTS STATE PLANE COORDINATE SYSTEM, NORTH AMERICAN DATUM, 1983 (NAD83).
- BASE SURVEY INFORMATION PROVIDED BY CITY OF SALEM AND MASSGIS.
- BENCHMARKS ARE NOT PROVIDED.
- FULL PERIMETERS AND EXTERIOR DIMENSIONS OF BUILDINGS NOT ACCURATELY SHOWN ON BASE SURVEY, CONTRACTOR TO CONFIRM DIMENSIONS AND FOOTPRINTS OF BUILDINGS BEFORE BEGINNING WORK CLOSE TO BUILDINGS AND ON PRIVATE PROPERTY.
- THE EXISTENCE, SIZE, LOCATION, ORIENTATION AND DESCRIPTION OF SEWER AND DRAIN STRUCTURES, PIPES, AND SERVICES, WATER VALVES AND MAINS, AND OTHER UTILITIES ARE FROM THE EXISTING INFORMATION PROVIDED, BUT ARE APPROXIMATE ONLY. THE CONTRACTOR SHALL VERIFY THE LOCATIONS OF ALL UNDERGROUND UTILITIES BEFORE EXCAVATING.
- ALL RIM AND INVERT ELEVATIONS ARE APPROXIMATE AND SHOWN TO WITHIN ONE TENTH OF A FOOT (0.1FT) PLUS OR MINUS 0.1FT.
- LINE FOR ALL SERVICES, POLICE AND FIRE ALARM BOXES, STREET LIGHTS, TRAFFIC SIGNALS AND OVERHEAD POWER, TELEPHONE AND CABLE TELEVISION LINES ARE NOT SHOWN ON THE PLANS. CONTRACTOR TO ASSUME ALL BUILDINGS AND HOMES ARE SERVED BY WATER, SEWER, GAS, ELECTRIC, AND TELECOMMUNICATION; AND SHALL PROTECT, RELOCATE, AND REPLACE SERVICES AS REQUIRED. THE APPROPRIATE UTILITY COMPANIES OR AUTHORITIES SHALL BE CONSULTED FOR LOCATIONS OF THE ABOVE, AND THE CONTRACTOR SHALL COORDINATE WITH THE OWNERS OF OTHER UTILITIES TO PROTECT AND SUPPORT (OR REMOVE AND REPLACE) ALL UTILITIES ENCOUNTERED DURING CONSTRUCTION.
- ALL BURIED UTILITIES (WATER, GAS, SEWER, DRAIN, ELECTRIC, TELECOMMUNICATION) ARE SHOWN SCHEMATICALLY AND NOT TO SCALE AND CANNOT BE USED TO SCALE OFF OUTSIDE PIPE DIAMETERS. CONTRACTOR TO ASSUME ALL BURIED ELECTRIC AND TELECOMMUNICATION UTILITIES ARE INSTALLED IN MULTIPLE CONDUIT DUCT BANKS AND MAY BE CONCRETE ENCASED. CONTRACTOR TO COMPLETE TEST PITS AND ADJUST LAYOUT AND MEANS AND METHODS TO AVOID CONFLICTS BETWEEN NEW AND EXISTING UTILITIES.
- ALL EROSION AND SEDIMENT CONTROL DEVICES SHALL BE INSTALLED AND APPROVED BY THE ENGINEER PRIOR TO THE COMMENCEMENT OF CONSTRUCTION. DEVICES SHALL INCLUDE AT A MINIMUM GEOTEXTILE (SILT SACK) IN ALL CATCH BASINS AND A BARRIER CONSISTING OF SILT FENCE OR MULCH SOCK AROUND SOIL STOCKPILES AND ALONG PROJECT BOUNDARY AS SHOWN ON PLANS AND AS DIRECTED. ALL CONSTRUCTION DEWATERING WATER MUST BE TREATED WITH A SEDIMENTATION TANK PRIOR TO DISCHARGE UPGRADIENT OF OTHER EROSION AND SEDIMENTATION DEVICES AND CONTROLS.
- CONTRACTOR SHALL MAINTAIN EDGE OF ROADWAY DRAINAGE PATTERNS INCLUDING REPLACEMENT OF PAVED AND UNPAVED SVALES, BERMS, AND CURBS.
- THE CONTRACTOR SHALL BE AWARE THAT BORINGS HAVE NOT BEEN COMPLETED FOR THIS PROJECT. THE EXISTING SUBSURFACE SOIL CONDITIONS AND GROUNDWATER LEVEL ARE NOT KNOWN, BUT GROUNDWATER LEVELS ARE ASSUMED TO BE HIGH AND HIGHLY VARIABLE DUE TO THE CLOSE PROXIMITY OF THE PROJECT TO RESOURCE AREAS AND THE RIVER WITH TIDAL IMPACTS. CONTRACTOR SHALL ANTICIPATE THAT REMOVAL AND DISPOSAL OF UNSUITABLE SOILS AND CONSTRUCTION DEWATERING DUE TO GROUNDWATER WILL BE REQUIRED DURING CONSTRUCTION THROUGHOUT THE PROJECT AREA, WITH INCREASED DEWATERING REQUIRED DURING RAINFALL AND HIGH TIDE CONDITIONS.
- CONTRACTOR SHALL BE AWARE THAT LEDGE IS KNOWN TO EXIST THROUGHOUT THE PROJECT AREA AND EXISTS ON THE MAJORITY OF THE PROJECT AREA. CONTRACTOR SHALL PLAN FOR ROCK EXCAVATION AND REMOVAL WITHIN THE EXCAVATIONS AND LINING PITS.
- CONTRACTOR SHALL BE AWARE THAT MANY "DRAIN" AND "SEWER" PIPES IN THE PROJECT AREA ARE COMBINED, WITH BOTH SANITARY SEWER AND STORMWATER FLOWS, AND ARE TIDALLY INFLUENCED WITH SALT WATER INFLOW/INFILTRATION DURING HIGHER TIDE CYCLES. CONTRACTOR SHALL ANTICIPATE BYPASS PUMPING WILL BE REQUIRED DURING CONSTRUCTION INVOLVING DRAIN AND SEWER PIPES, WITH INCREASED PUMPING REQUIRED DURING RAINFALL AND HIGH TIDE CONDITIONS.
- DIVERSION AND CONTROL OF EXISTING SANITARY, STORM SEWER, PROCESS WATER AND PROCESS DRAIN FLOWS AND DEWATERING ARE THE RESPONSIBILITY OF THE CONTRACTOR. THE CONTRACTOR'S INTENDED METHODS FOR DIVERSION AND CONTROL AND DEWATERING SHALL BE SUBMITTED TO THE ENGINEER FOR REVIEW AND APPROVAL. BYPASS HOSES SHALL NOT BE ALLOWED TO LEAK AND SURFACE WATER RELATING TO CONSTRUCTION OPERATIONS SHALL BE PREVENTED FROM FREEZING.
- THE CONTRACTOR SHALL PROVIDE METHODS TO BE EMPLOYED DURING DEWATERING OPERATIONS AND FOR STORM WATER RUNOFF NOT TO ALLOW SILT OR DEBRIS TO ENTER EXISTING DRAINAGE FACILITIES OR CREATE NUISANCES. THE CONTRACTOR SHALL BE RESPONSIBLE FOR CLEANING EXISTING OR NEW FACILITIES IF SILTATION OCCURS DUE TO THE CONTRACTOR'S OPERATIONS.
- EXISTING PAVEMENT THICKNESS, SIDEWALK MATERIALS, AND SUBBASE MATERIALS VARY AND MAY INCLUDE MULTIPLE, VARIED PAVEMENT MATERIALS, AND COBBLESTONES. ROADWAY LAYOUTS MAY HAVE PREVIOUSLY INCLUDED TROLLEY/TRAIN TRACKS AND MAY STILL INCLUDE COBBLES, TROLLEY TRACKS, AND TIMBERS.
- CONTRACTOR SHALL COORDINATE WITH THE PHONE AND CABLE COMPANIES TO ARRANGE AND SCHEDULE CONSTRUCTION TO AVOID IMPACTS ON EXISTING PHONE/CABLE UTILITIES AND/OR ALLOW PHONE/CABLE COMPANY ACCESS TO THE PROJECT SITE TO SUPPORT/RELOCATE THEIR UTILITIES AS REQUIRED.
- BEFORE EXCAVATING, BACKFILLING, CRADING, PAVEMENT RESTORATION OR REPAIRING, ALL UTILITY COMPANIES, PUBLIC AND PRIVATE, MUST BE CONTACTED, INCLUDING THOSE IN CONTROL OF UTILITIES NOT SHOWN ON THESE PLANS. SEE CHAPTER 370, ACT OF 1963, MASSACHUSETTS GENERAL LAWS. THE CONTRACTOR SHALL PREMARK THE EXCAVATION AREA IN WHITE PAINT PRIOR TO CALLING THE DIG SAFE CENTER (TEL. NO. 1-888-DIG-SAFE). THE CONTRACTOR SHALL CONTACT THE DIG SAFE CENTER AT LEAST THREE BUSINESS DAYS PRIOR TO ANY EXCAVATION, AND NOTIFY ALL AFFECTED PRIVATE AND/OR PUBLIC UTILITIES TO PERMIT STREET MARKING OF THEIR LINES. THE OWNER AND ENGINEER ASSUME NO RESPONSIBILITY FOR DAMAGES INCURRED AS A RESULT OF UTILITIES OMITTED OR INACCURATELY SHOWN.
- IF THE CONTRACTOR DAMAGES UTILITY SERVICES, HE SHALL IMMEDIATELY NOTIFY THE RESPECTIVE UTILITY COMPANY AND SHALL IMMEDIATELY REPLACE OR REPAIR.
- WHERE UTILITY RELOCATION IS REQUIRED, THE CONTRACTOR SHALL NOTIFY THE AFFECTED UTILITY COMPANY AT LEAST 30 DAYS IN ADVANCE OF CONSTRUCTION AND SHALL COORDINATE THE PROPOSED WORK WITH THE UTILITY RELOCATION.
- THE CONTRACTOR SHALL VERIFY EXISTING CONDITIONS INFORMATION AND REPORT ANY DISCREPANCIES BETWEEN THE PLANS AND THE ACTUAL CONDITIONS TO THE ENGINEER PRIOR TO BEGINNING WORK. THE CONTRACTOR'S ATTENTION IS DIRECTED TO EXISTING LABELED SEWER MANHOLE OR DRAIN MANHOLE COVERS SHOWN ON THE PLANS AS THEY MAY NOT ACCURATELY REPRESENT THE UNDERGROUND SERVICE. PRIOR TO ANY WORK THE CONTRACTOR SHALL NOTIFY THE ENGINEER OF AN EXISTING COVER NOT ACCURATELY REPRESENTING THE SERVICE BELOW.
- EXPLORATORY EXCAVATIONS (TEST PITS) SHALL BE EXCAVATED AT THOSE LOCATIONS INDICATED ON THE PLANS AND WHERE ORDERED AND APPROVED BY THE OWNER OR OWNER'S REPRESENTATIVE. TEST PIT EXCAVATIONS SHALL BE MADE TO DETERMINE THE LOCATIONS OF ALL EXISTING UTILITIES OR STRUCTURES IN ADVANCE OF CONSTRUCTION OPERATIONS AND TO IDENTIFY POTENTIAL CONFLICTS SO THAT ANY REQUIRED CHANGES IN ALIGNMENT AND/OR GRADE OF THE PROPOSED WORK OR UTILITY LOCATIONS MAY BE DETERMINED. ALL DECISIONS RELATIVE TO UTILITY CONFLICTS AND RELOCATION REQUIREMENTS WILL BE MADE BY THE RESIDENT ENGINEER. TEST PITS MAY NOT BE COMPLETED TOO FAR IN ADVANCE OF PIPELINE INSTALLATION, AUTHORIZATION REQUIRED FROM ENGINEER TO BEGIN TEST PITS ON EACH STREET OR IN EACH WORK AREA.
- EXISTING PIPE SIZE AND MATERIAL ARE APPROXIMATE AND MAY HAVE DIFFERING HORIZONTAL AND/OR VERTICAL DIMENSIONS DEPENDING ON THE SHAPE (EGG-SHAPED, TEAR-DROP, ETC.). EXISTING PIPES MAY BE SLIPLINED IN LARGER PIPES OF DIFFERENT MATERIAL.
- CONTRACTOR TO PROTECT AND SUPPORT OR REMOVE AND REPLACE SIGNS, POSTS, HYDRANTS, FENCES, GATES, UTILITY POLES, OR OTHER SURFACE FEATURES THAT OBSTRUCT CONSTRUCTION OPERATIONS OR ARE DAMAGED BY CONSTRUCTION. AREAS DISTURBED DURING CONSTRUCTION SHALL BE RESTORED BY THE CONTRACTOR TO THEIR ORIGINAL CONDITION AT THE CONTRACTOR'S EXPENSE. DAMAGE OF PROPERTY BEYOND THE WORK LIMITS CAUSED BY THE CONTRACTOR'S OPERATIONS SHALL BE REPAIRED BY THE CONTRACTOR
- CONTRACTOR RESPONSIBLE TO REMOVE, PROTECT, AND REPLACE ALL SURFACE FEATURES OFF ROAD INCLUDING SIGNS, MAILBOXES, WALKS, PAVEMENT, STONES, PLANTINGS, AND MULCH.
- NOT ALL GAS AND SEWER SERVICE LINES NOT SHOWN ON PLAN. CONTRACTOR TO ASSUME EACH BUILDING HAS, AT A MINIMUM, ONE GAS SERVICE AND ONE SEWER SERVICE LINE CONNECTED TO MAINS IN STREET.
- CONTRACTOR TO SCHEDULE NEW WATER MAIN INSTALLATIONS AND ADJUST LAYOUT OF NEW WATER MAINS IN THE FIELD TO AVOID CONFLICTS WITH GAS MAIN, EXISTING UTILITIES.
- ALL TEMPORARY WATER BYPASS TO BE LOOPED BETWEEN TWO FEED LOCATIONS. CONTRACTOR TO INSTALL 8" FEED LOCATIONS AS SHOWN ON PLANS.

**LEGEND**

	EXPLORATORY EXCAVATION/TEST PIT		
	LINING PIT LOCATION		
	NEW GATE VALVE		
	NEW HYDRANT		
	NEW WATER TEE		
	INSPECT AND CIPP LINE WATER MAIN		
	NEW WATER MAIN WITH COUPLINGS		
	NEW WATER SERVICE WITH NEW CURB STOP WITH COUPLINGS		
	NEW RISER STRUCTURE WITH "WATER" COVER		
	EROSION AND SEDIMENTATION BARRIER		
	TELECOMMUNICATION UTILITY CONDUIT WITH MANHOLE		
	ELECTRIC UTILITY CONDUIT		
	GAS MAIN WITH MAIN LINE VALVE AND CAPPED END		
	SEWER PIPE WITH SIZE & MATERIAL, SEWER MANHOLE		
	DRAIN PIPE WITH PIPE SIZE & MATERIAL, DRAIN MANHOLE		
	WATER MAIN WITH PIPE SIZE & MATERIAL, MAIN LINE VALVE, WATER SERVICE & CURB STOP		
	PARCEL/PROPERTY LINE		
	GUARDRAIL		
	VEGETATION BOUNDARY		
	CONTOUR ELEVATION LINE WITH LABEL (FEET)		
	ELEVATION SPOT GRADE (FEET)		
	STRUCTURE/BUILDING		
AC	ASBESTOS CEMENT		CATCHBASIN
BIT.	BITUMINOUS		HYDRANT
CB	CATCHBASIN		TREE
CI	CAST IRON		UTILITY POLE WITH IDENTIFICATION NUMBER
CNL	CANNOT LOCATE		ELECTRIC HANDHOLE
CONC.	CONCRETE		
DI	ASBESTOS CEMENT		
DMH	DRAIN MANHOLE		
ELEC.	ELECTRIC		
GV	GATE VALVE		STREET SIGN
GVC	GRANITE VERTICAL CURB		TRAFFIC/STREET LIGHT
MIN.	MINIMUM		
NTS	NOT TO SCALE		
PED.	PEDESTRIAN		
PVC	POLYVINYL CHLORIDE		
RCP	REINFORCED CONCRETE PIPE		
SMH	SEWER MANHOLE		
UNK.	UNKNOWN		
VC	VITRIFIED CLAY		
D	DRAIN		
E	ELECTRIC		
G	GAS		
S	SEWER		
T	TELECOMMUNICATION		

Client	<b>CITY OF SALEM, MASSACHUSETTS</b>			Scale	NTS		
Project	<b>HIGHLAND AVENUE WATER LINING PROJECT</b>			Date	11/12/2020		
<b>GENERAL NOTES</b>				Job	Salem-HighlandW/Lining		
				Designed by	WMR		
				Drawn by	RLM		
				Checked by	No.	Description	Date
				Approved by	File: W:\Salem\Water Work\Highland Avenue\CAD Drawings\HighlandCIP\Lining.dwg		
			<b>New England Civil Engineering Corp.</b>	Sheet			
			<b>265 Essex Street, Suite 102 SALEM, MASSACHUSETTS</b>	<b>G-2</b>			

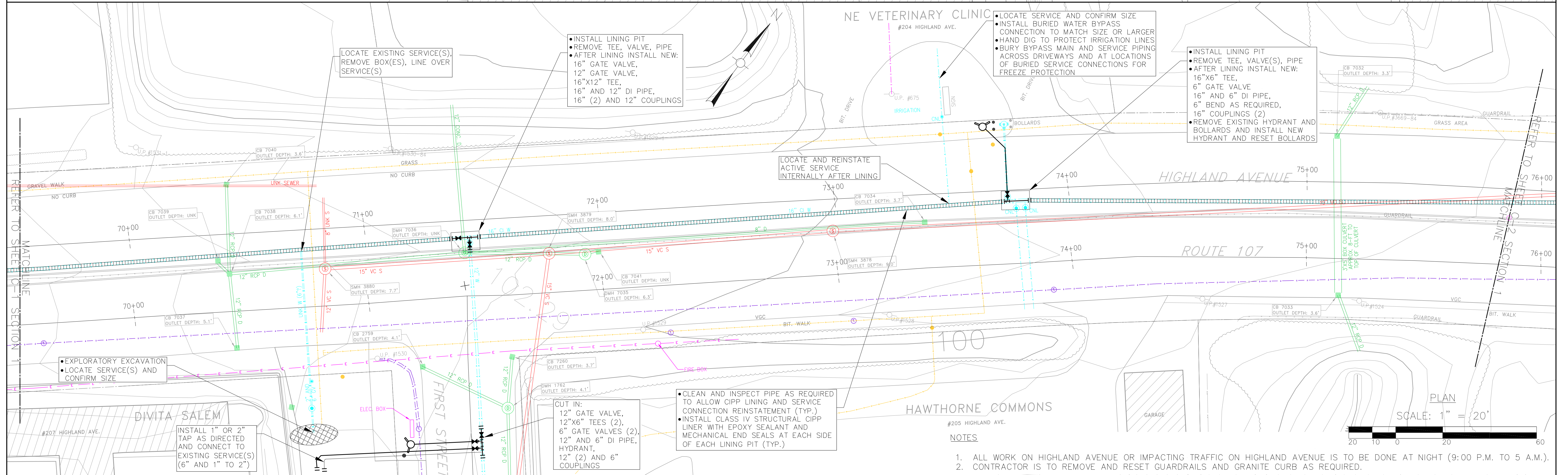
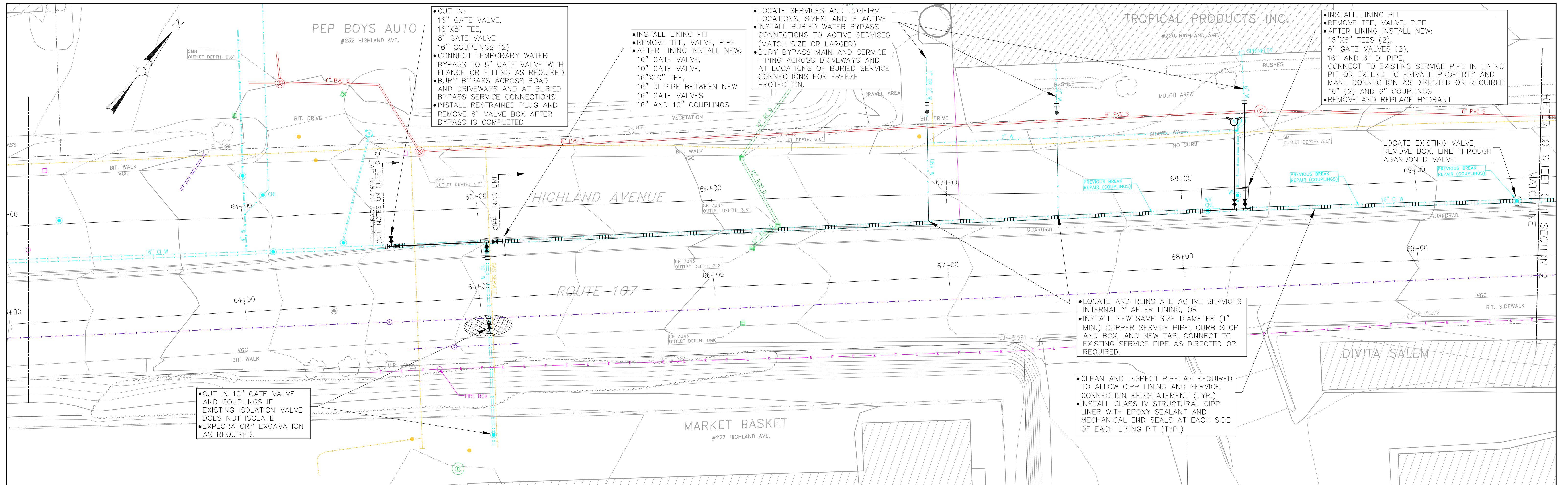

- NOTES
- ALL WORK ON HIGHLAND AVENUE OR IMPACTING TRAFFIC ON HIGHLAND AVENUE IS TO BE DONE AT NIGHT (9:00 P.M. TO 5 A.M.).
  - CONTRACTOR IS TO REMOVE AND RESET GUARDRAILS AND GRANITE CURB AS REQUIRED.

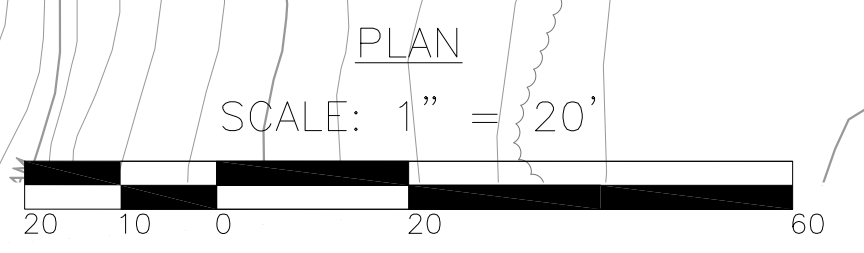

Client  
**CITY OF SALEM, MASSACHUSETTS**

Project  
**HIGHLAND AVENUE WATER LINING PROJECT**

**UTILITY PLAN**

Scale  
**1"=20"**

Date  
**11/12/2020**

Job  
**Salem-HighlandWaterLining**

Designed by  
**WMR**

Drawn by  
**RLM**

Checked by

Approved by

No. \_\_\_\_\_ Description \_\_\_\_\_ Date \_\_\_\_\_

File: W:\Salem\Water Work\Highland Avenue\CAD Drawings\HighlandCIP\Lining.dwg

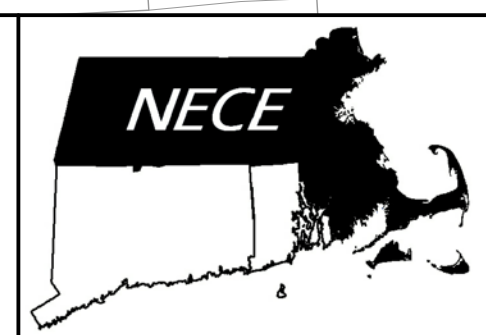
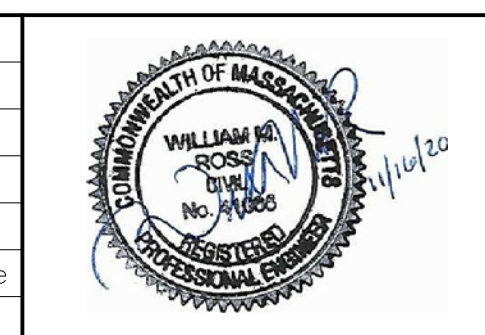

**New England Civil Engineering Corp.**

265 Essex Street, Suite 102  
SALEM, MASSACHUSETTS

Sheet  
**C-1**

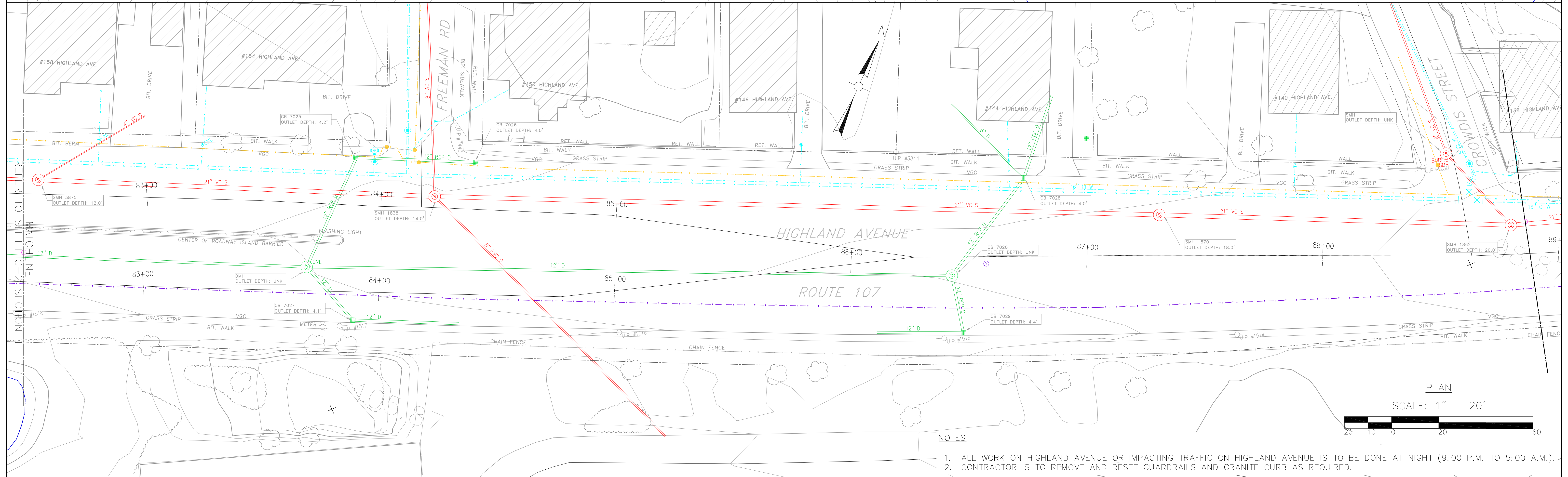
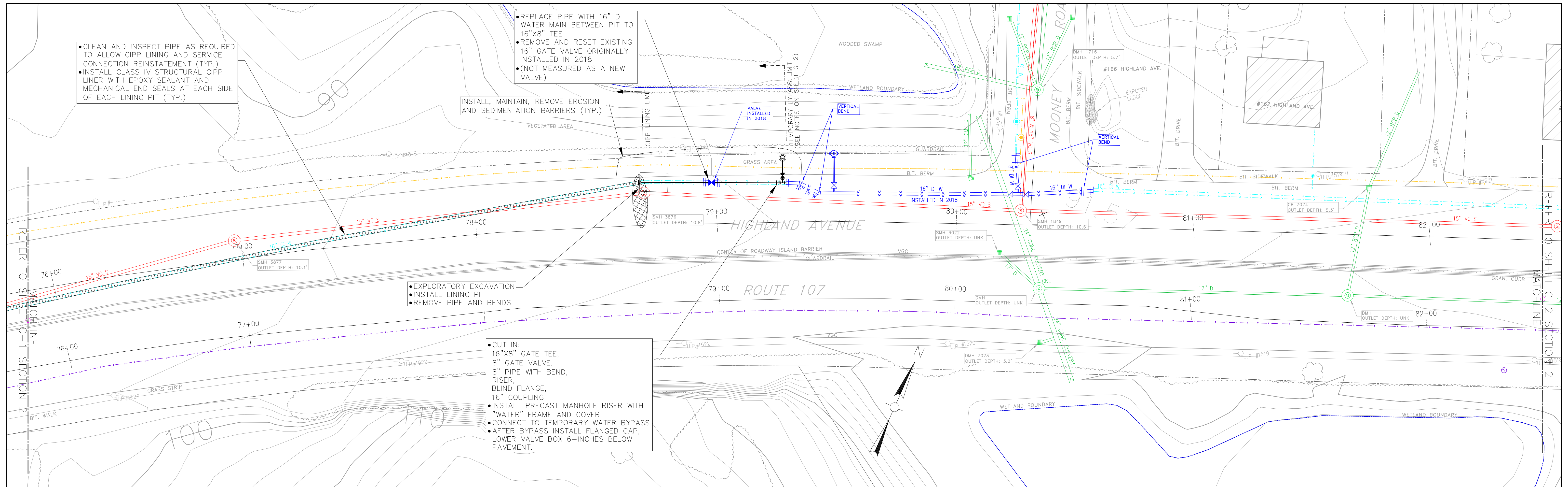

Client	CITY OF SALEM, MASSACHUSETTS
Project	HIGHLAND AVENUE WATER LINING PROJECT
	UTILITY PLAN

Scale	1"=20"
Date	11/12/2020
Job	Salem-HighlandW/Lining
Designed by	WMR
Drawn by	RLM
Checked by	
Approved by	
No.	
Description	
Date	
File:	W:\Salem\Water Work\Highland Avenue\CAD Drawings\HighlandCIP/Lining.dwg

		<b>New England Civil Engineering Corp.</b> 265 Essex Street, Suite 102 SALEM, MASSACHUSETTS	Sheet <b>C-2</b>

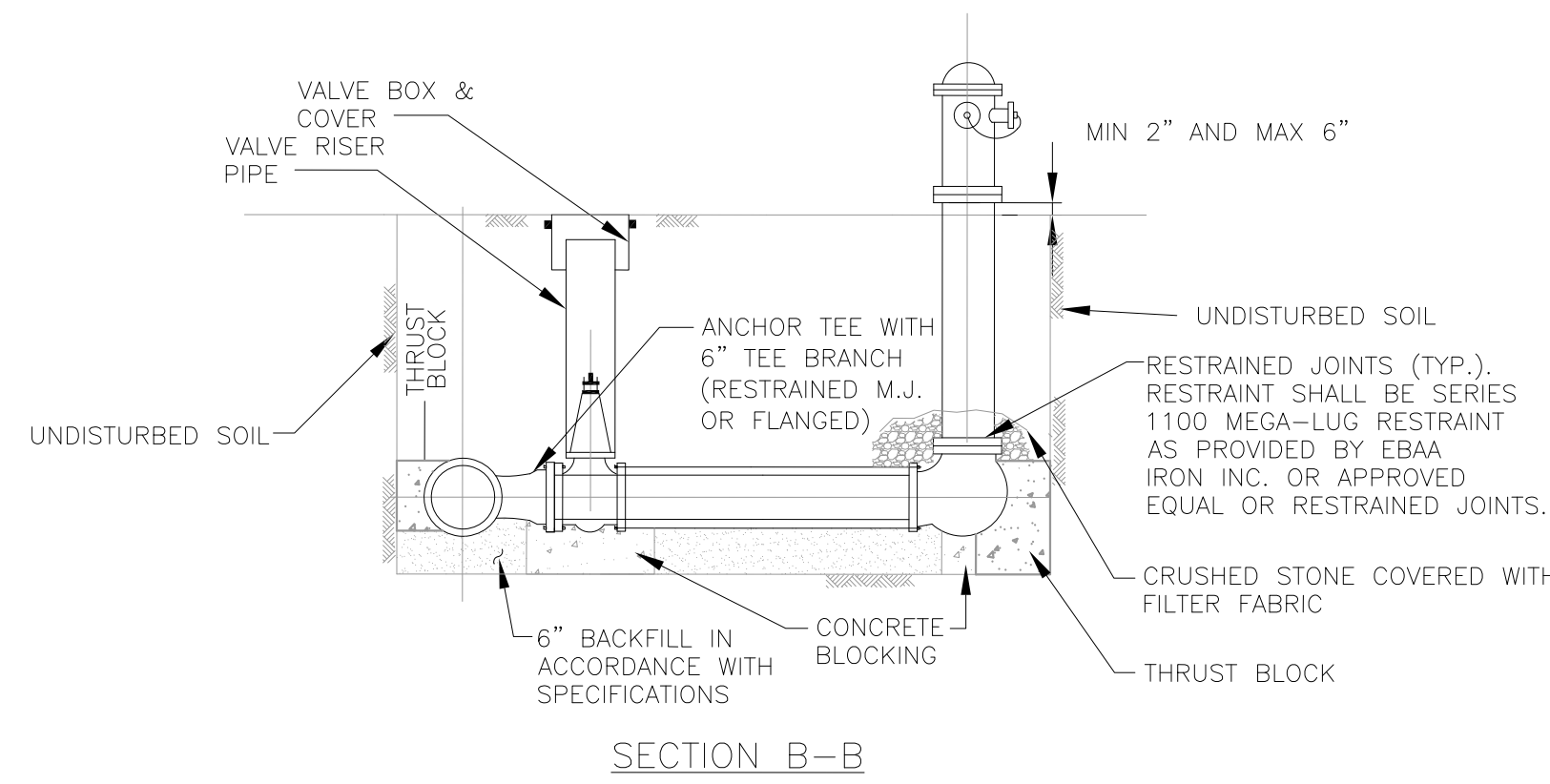
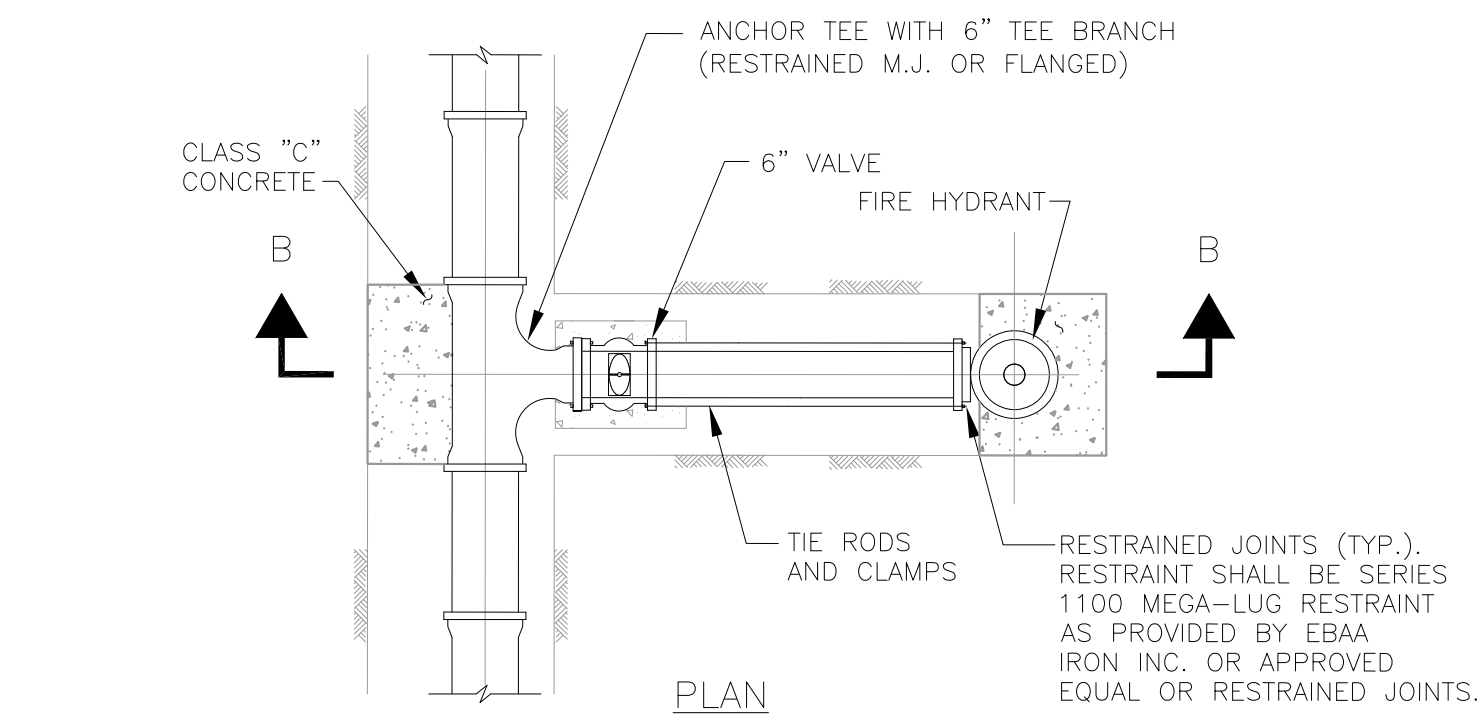

**FIRE HYDRANT DETAIL**

NOT TO SCALE

- NOTES:
1. LOCATE FIRE HYDRANTS AS SHOWN ON DRAWINGS, APPROXIMATELY 3 FEET BEHIND CURB OR PROJECTED FUTURE CURB.
  2. THE FIRE HYDRANT STEAMER NOZZLE SHALL FACE THE STREET.
  3. REFER TO SPECIFICATION SECTION 03300 FOR CONCRETE (3,000 PSI) THRUST BLOCKS.
  4. PROVIDE HYDRANT, VALVE AND TEE JOINTS WITH RESTRAINED MECHANICAL JOINTS AND RODS AND CLAMPS.
  5. HYDRANTS TO BE 5'6" BURY DEPTH UNLESS DIRECTED OTHERWISE.

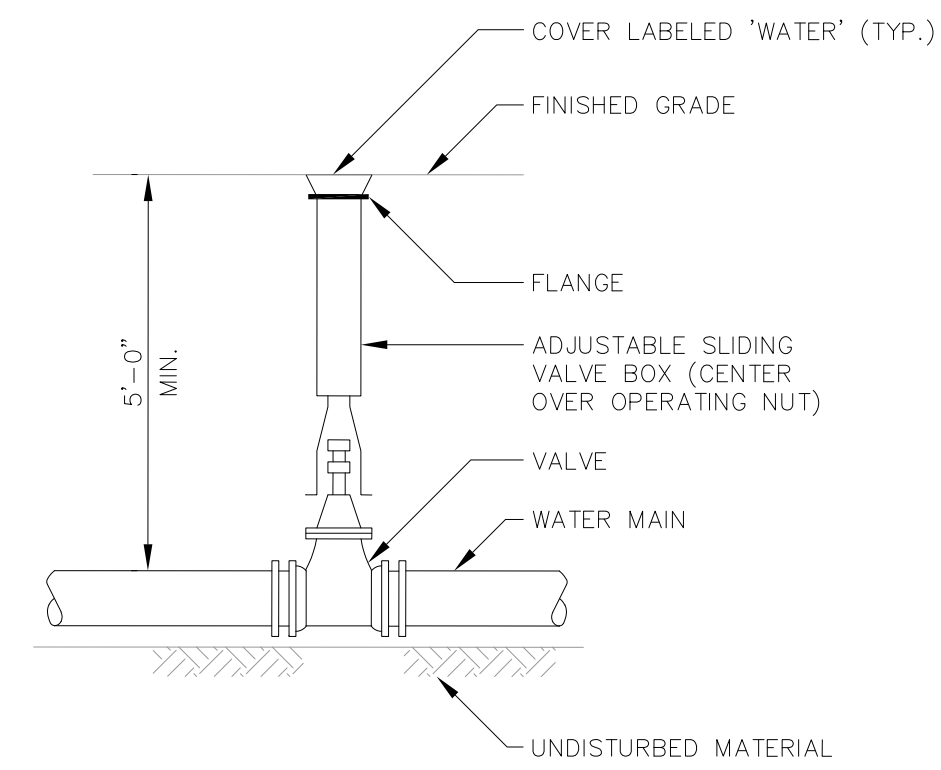

**TYPICAL VALVE BOX DETAIL**

NOT TO SCALE

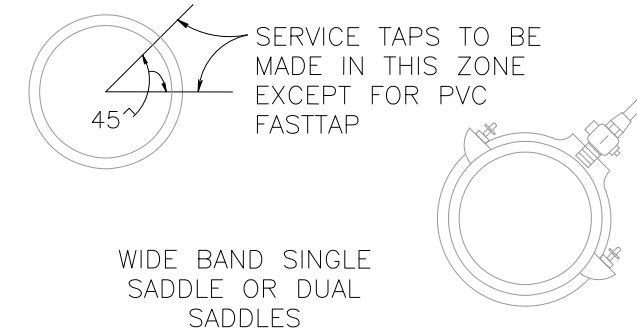

**SERVICE CONNECTION**

NOT TO SCALE

- NOTES:
1. BLOW-OFF & CHLORINATION TAPS ARE MADE IN VERTICAL POSITION

PIPE TAPPING SCHEDULE	
WATER MAIN TYPE AND DIAMETER	SERVICE TAP TYPE
12" OR LESS CAST IRON OR DUCTILE IRON	DSS, WBSS
16" AND UP CAST IRON OR DUCTILE IRON	DWBSS

DSS - DUAL STRAP SADDLES  
WBSS - WIDE BAND STRAP SADDLES  
DWBSS - DUAL WIDE BAND STRAP SADDLES

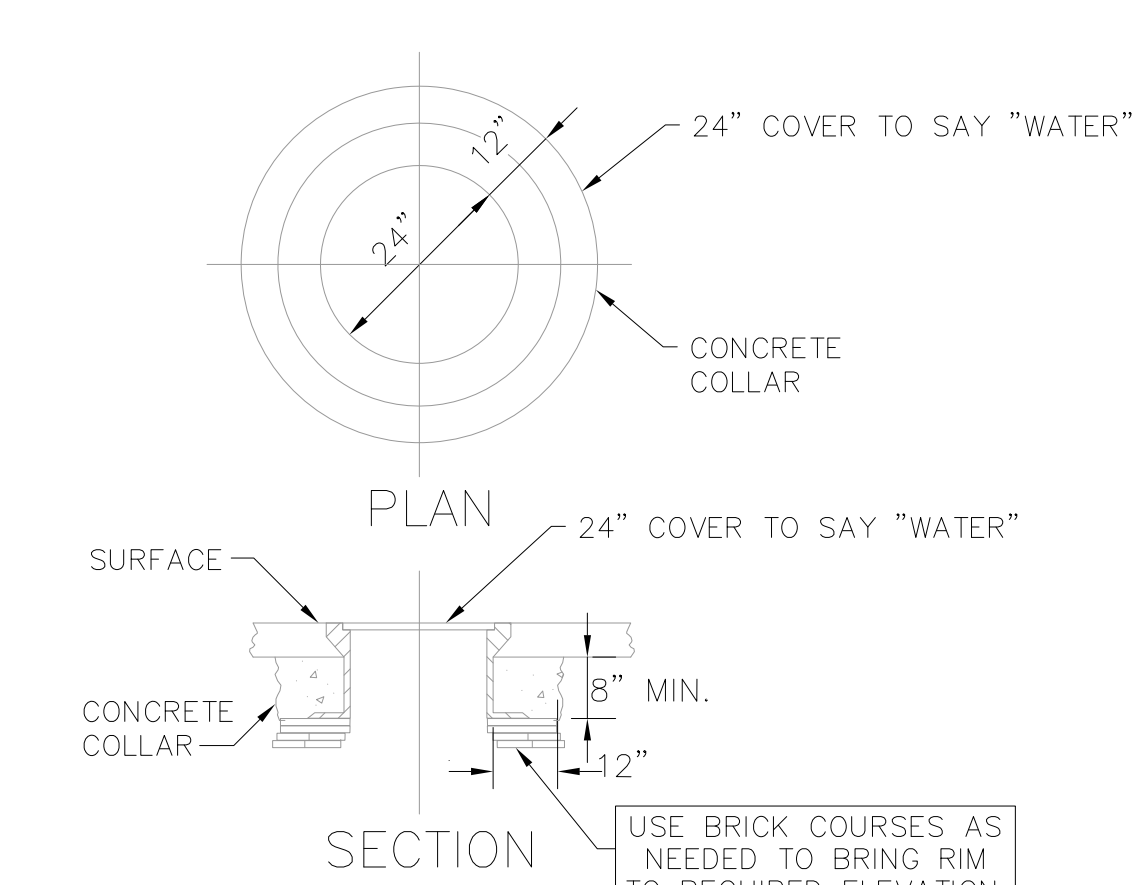

**MANHOLE FRAME AND COVER**

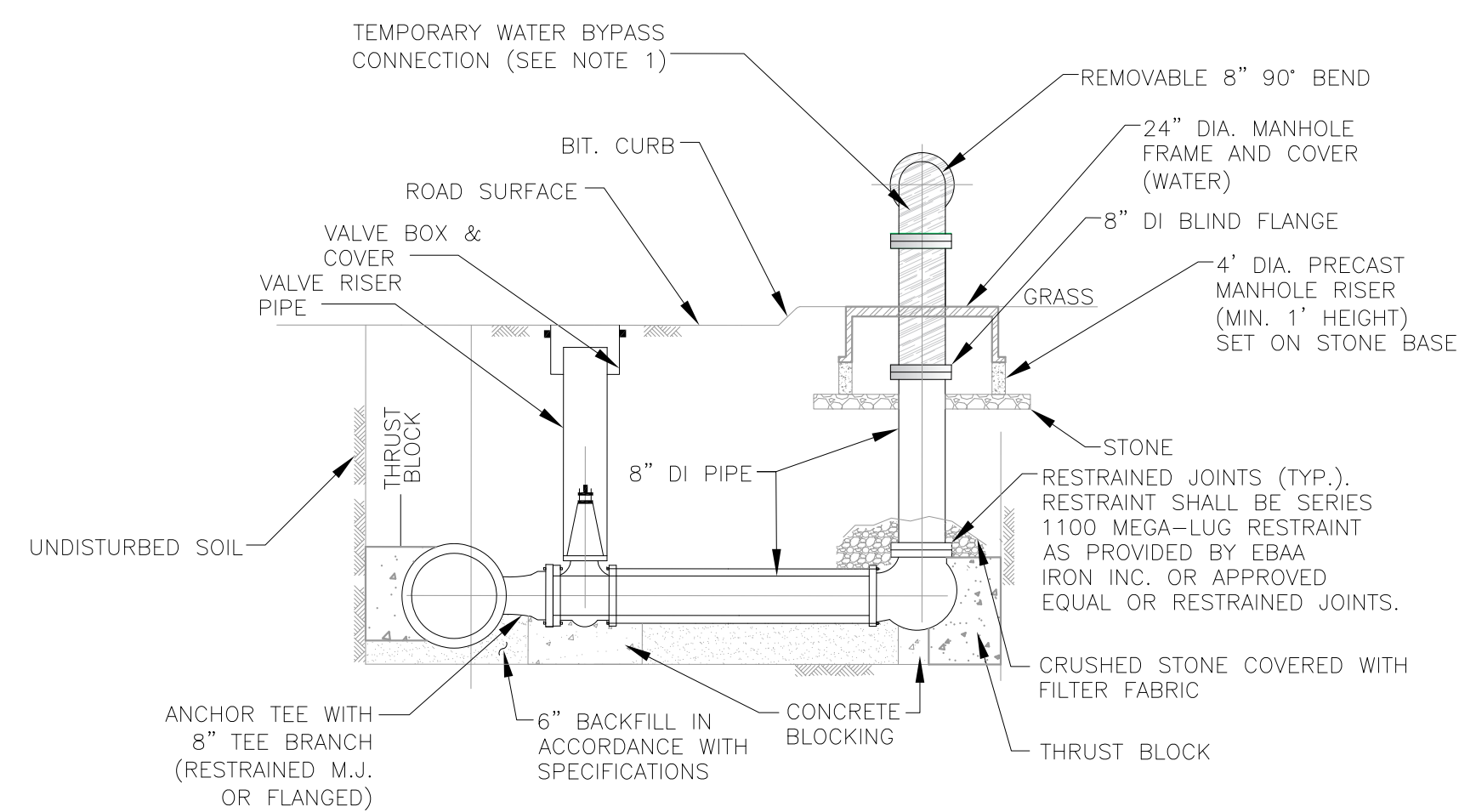

**BYPASS CONNECTION FOR TEMPORARY BYPASS PIPING AND FUTURE USE**

NOT TO SCALE

NOTE: INSTALL RESTRAINED CAP

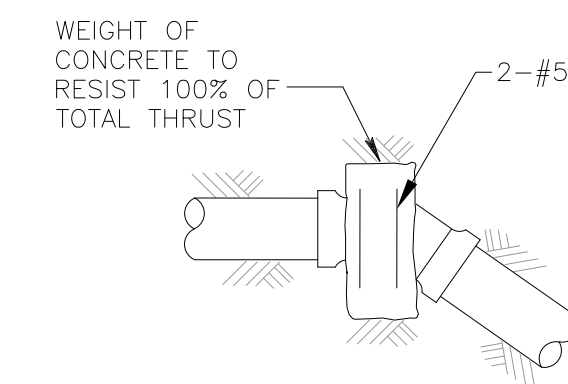

**VERTICAL BEND**

NOTE: CONC. FOR THRUST BLOCKS TO BE 3000 P.S.I

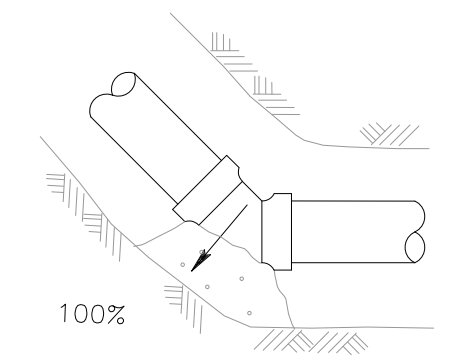

**HORIZONTAL BEND**

NOTE: FIGURE (100%) AT THRUST BLOCK INDICATES PERCENT OF TOTAL THRUST TO BE APPLIED FOR BEARING AREA.

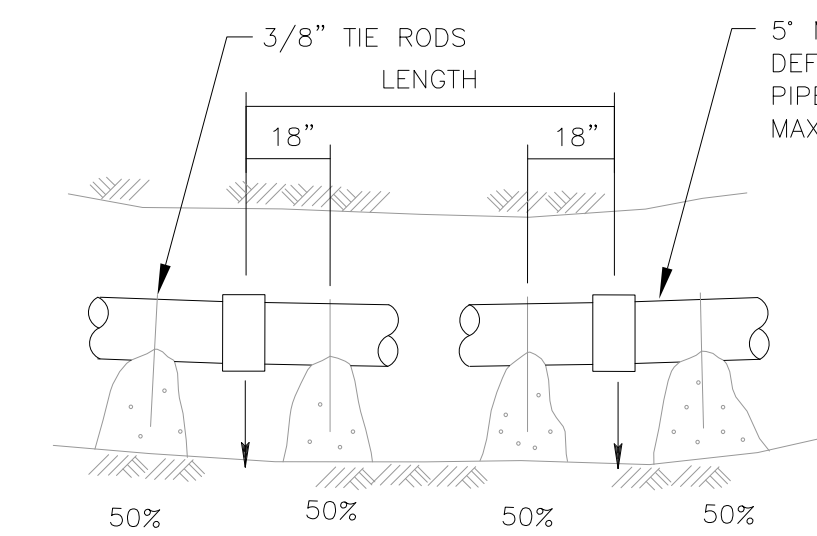

**CURVE THRUST BLOCKING**

**CONCRETE THRUST BLOCKS FOR DUCTILE IRON PIPE**

NOT TO SCALE

PIPE SIZE	THRUST PER PSI OF WATER PRESSURE AT VARIOUS FITTINGS			
	DEAD END OR TEE	90° ELBOW	45° ELBOW	22 1/2° ELBOW
6	39	55	30	15
8	67	94	51	26
10	109	154	84	43
12	155	218	119	61
16	275	383	209	106
18	351	494	269	137

EXAMPLE:

8-INCH 90° ELBOW. PRESSURE=200lb./SQ.IN.  
FROM TABLE: THRUST=94 x 200=18,800 lb.  
ASSUME BEARING STRENGTH OF SOIL=2000 lb./SQ.FT.

18,800 / 2000 = 9.4 SQ.FT. = AREA OF BEARING REQUIRED FOR THRUST BLOCK

PIPE SIZE-in.	SIDE THRUST PER 100 lb./sq.in. PRESSURE PER DEGREE OF DEFLECTION		
	90°	45°	22 1/2°
6	72	12	278
8	122	16	486
10	197	18	665

- NOTES:
1. IN USING THE ABOVE TABLES, USE THE MAXIMUM INTERNAL PRESSURE ANTICIPATED (i.e. HYDROSTATIC TEST PRESSURE, POSSIBLE SURGE PRESSURE DUE TO PUMP SHUT-OFF, ETC.
  2. ASSUME A SOIL BEARING STRENGTH OF 2000 LB. PER SQ. FOOT.
  3. JOINTS SHALL BE PROTECTED BY FELT ROOFING PAPER PRIOR TO PLACING CONCRETE.
  4. REFER TO SPECIFICATION SECTION 03300 - CONCRETE FOR CONCRETE REQUIREMENTS

MULTIPLY THRUST BY DEGREE OF DEFLECTION TO OBTAIN TOTAL THRUST

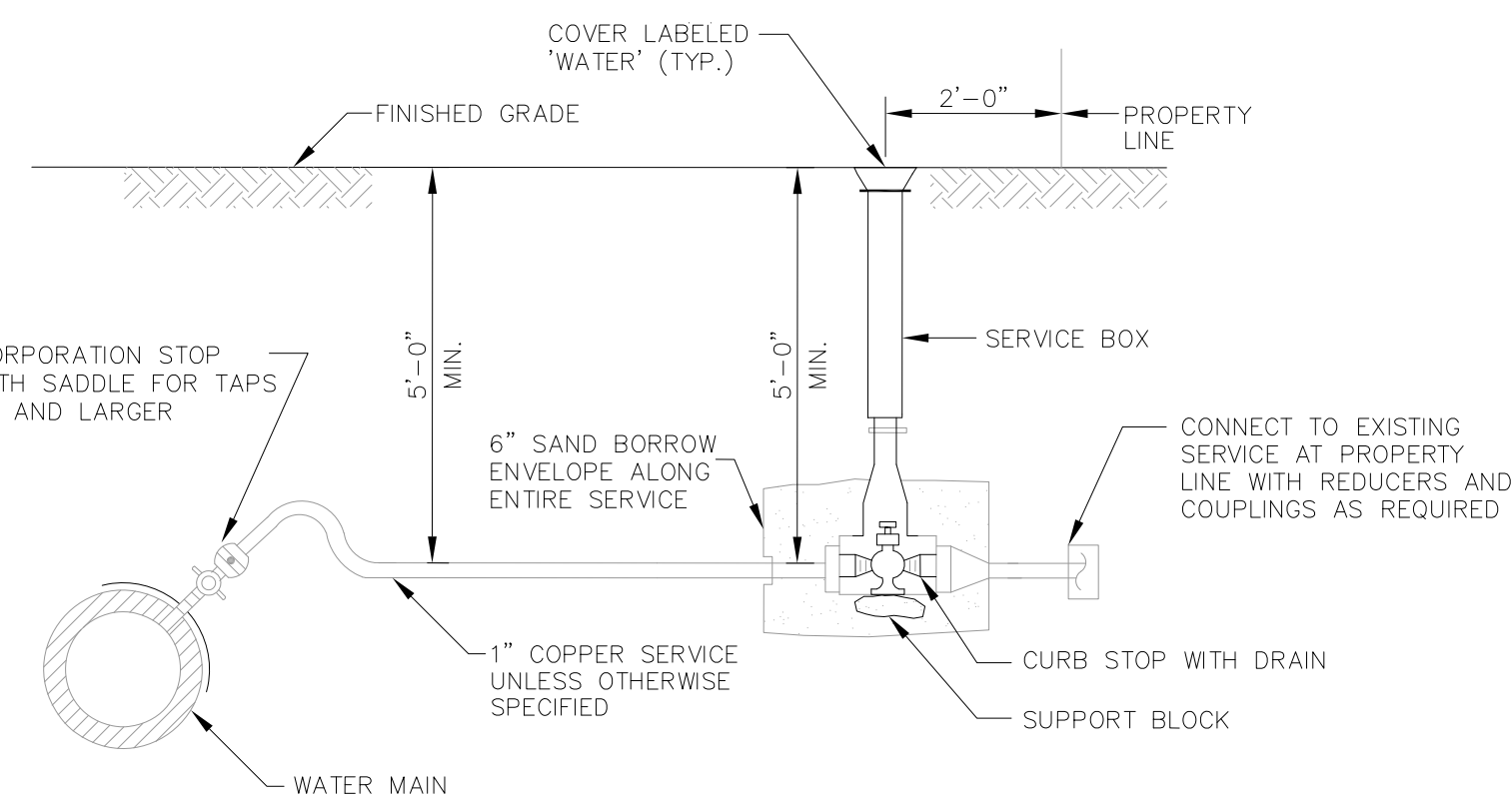

**COPPER SERVICE CONNECTION DETAIL**

NOT TO SCALE

- NOTES:
1. FLUSH ALL NEW SERVICE LINES PRIOR TO CONNECTING TO EXISTING.
  2. AFTER CONNECTION, CONTRACTOR SHALL ASSIST WATER DEPT. PERSONNEL IN FLUSHING SERVICE LINES UP TO THE METER.
  3. COPPER SERVICE TO BE INSTALLED IN 6-INCH SAND ENVELOPE.
  4. CONNECT TO EXISTING SERVICE. WHERE EXISTING SERVICES DO NOT EXIST, PLUG END OF CURB STOP.
  5. ALL NEW COPPER SERVICES TO BE CONTINUOUS WITHOUT UNIONS OR COUPLINGS BETWEEN CORPORATION AND CURB STOP.

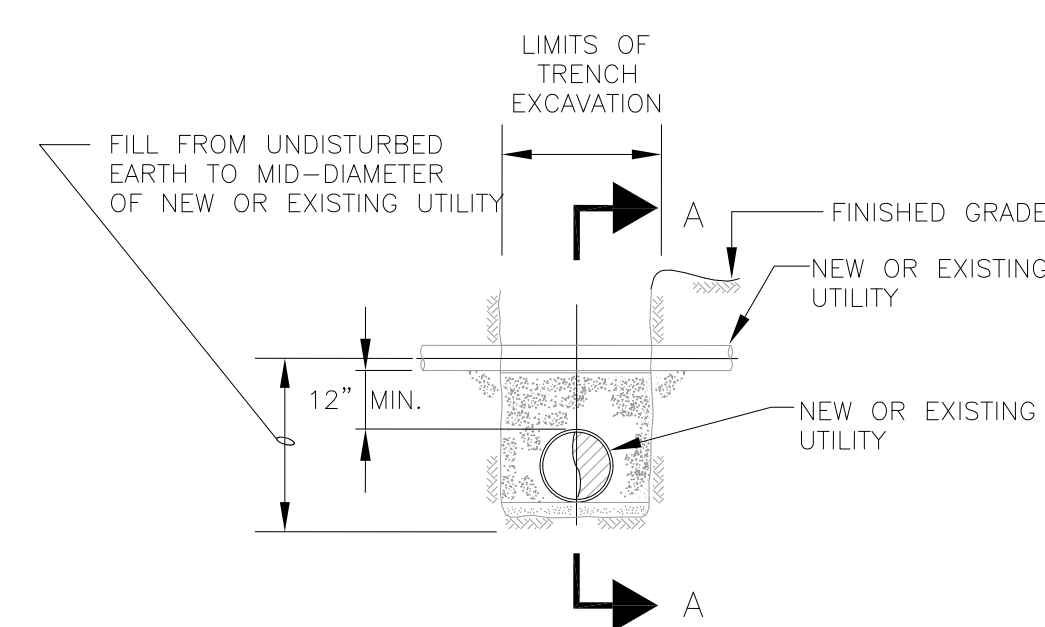

**UTILITY CROSSING DETAIL**

NOT TO SCALE

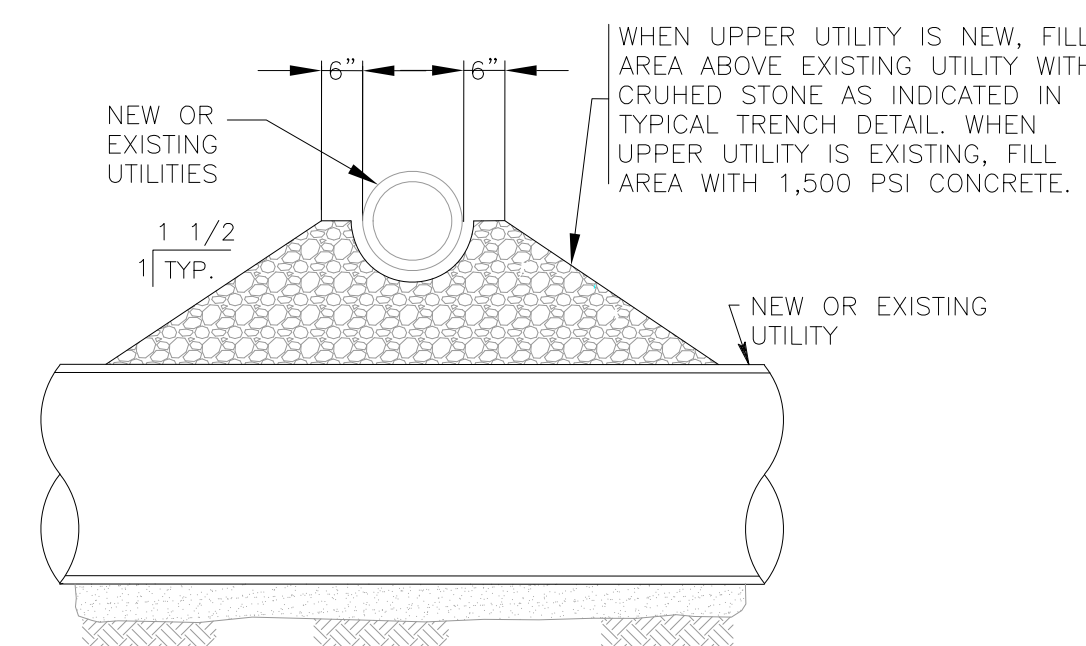

**SECTION A-A**

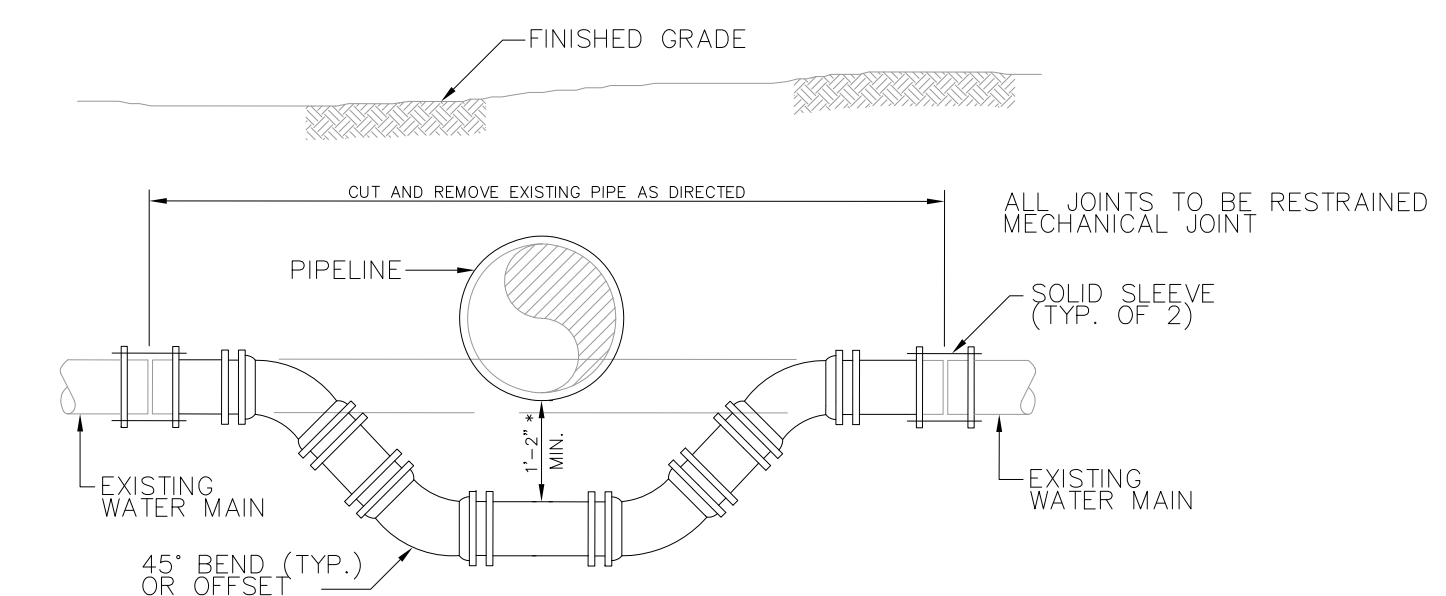

**RELOCATION OF EXISTING WATER MAIN DETAIL**

NOT TO SCALE

\*FOR SEWER CROSSINGS, RELOCATE MAIN ABOVE SEWER (WHERE POSSIBLE) AND PROVIDE 18" MINIMUM CLEARANCE.

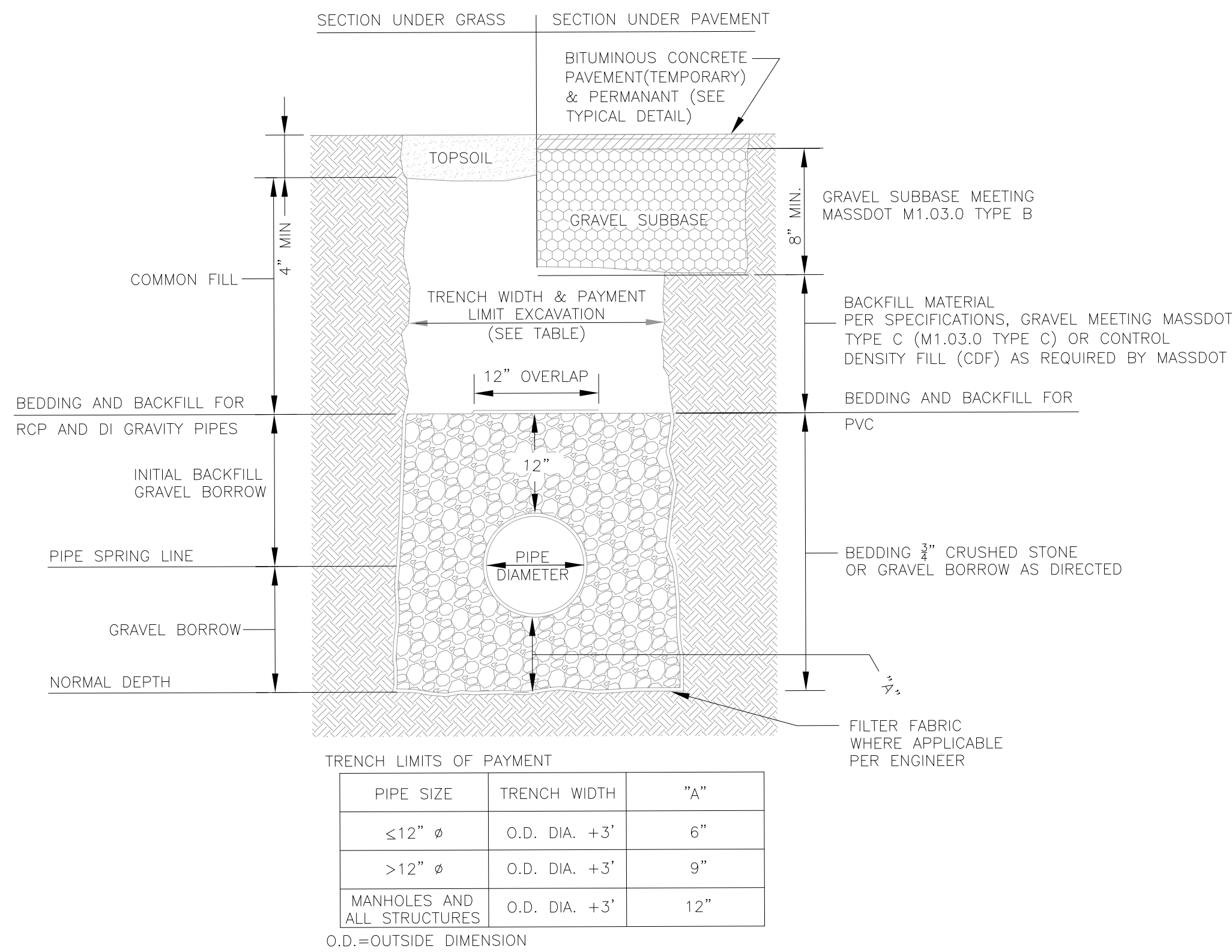

**TRENCH DETAIL**

NOT TO SCALE

- NOTES:
- REFER TO SPEC. SECTION 02500-PAVING AND SURFACING, MASSDOT STANDARD SPECIFICATIONS FOR HIGHWAYS AND BRIDGES, AND PAVEMENT DETAILS FOR PAVEMENT AND BASE COURSE REQUIREMENTS.
  - REFER TO SPEC. SECTION 02200-EARTH EXCAVATION, BACKFILL, FILL, GRADING AND FOR BEDDING AND BACKFILL MATERIAL REQUIREMENTS.
  - FOR USE IN PAYMENT OF ALL ITEMS IN WHICH PAY TRENCH WIDTH IS A VARIABLE FOR THE CALCULATION OF QUANTITIES.
  - BEDDING SHALL BE PER TABLE UNLESS OTHERWISE INDICATED.
  - METAL FOIL MARKING TAPE TO BE PLACE ABOVE WATER PIPE AND SERVICES (MIN. 18" SEPARATION)

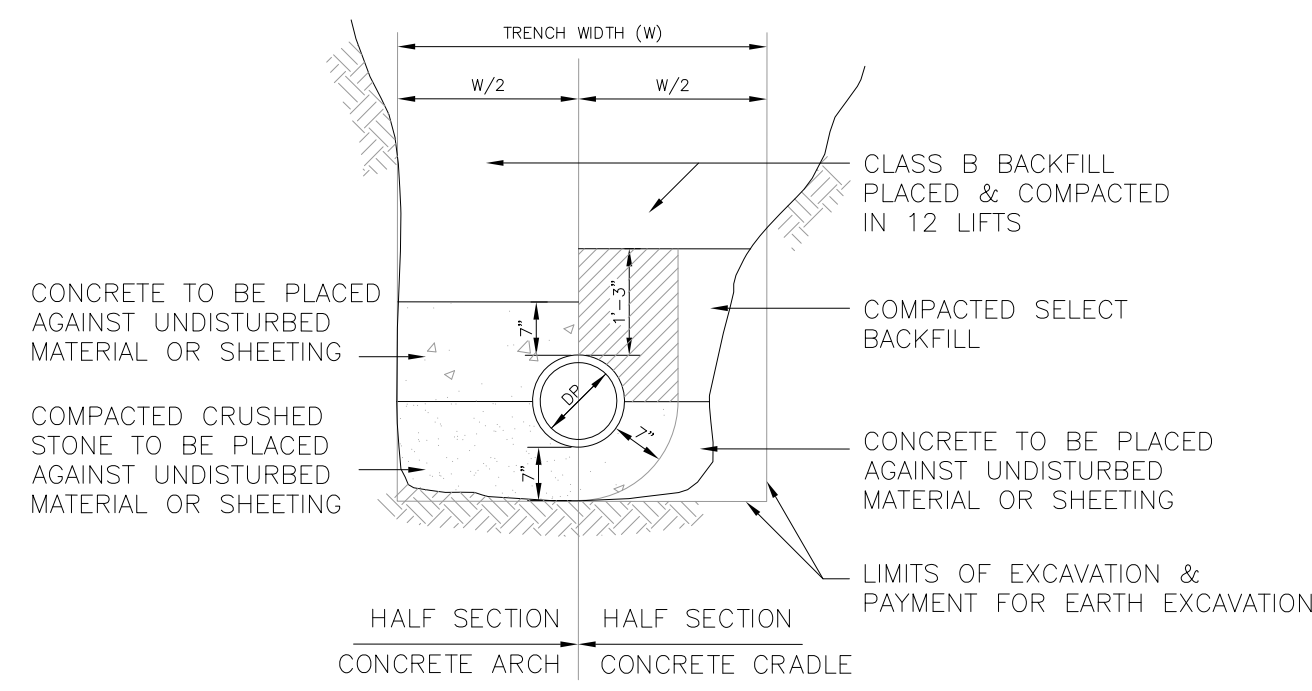

NOTE:  
IF CONCRETE ENGAGEMENT IS REQUIRED, CONCRETE OF 6" MINIMUM THICKNESS SHALL BE PLACED ALL AROUND PIPE.

**CONCRETE ARCH AND CRADLE DETAIL**

NOT TO SCALE

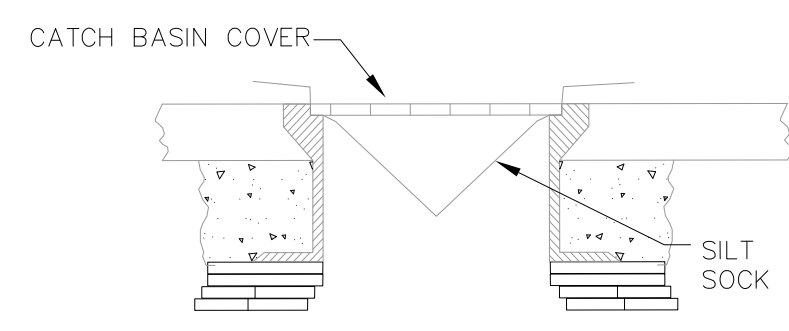

INSTALL SEDIMENTATION BARRIER IN EACH CATCH BASIN ALONG THE WATERMAIN ROUTE. UPON PAVING OF TRENCH, REMOVE SILT AND DEBRIS THEN REMOVE FILTER FABRIC.

**CATCH BASIN SEDIMENTATION BARRIER**

NOT TO SCALE

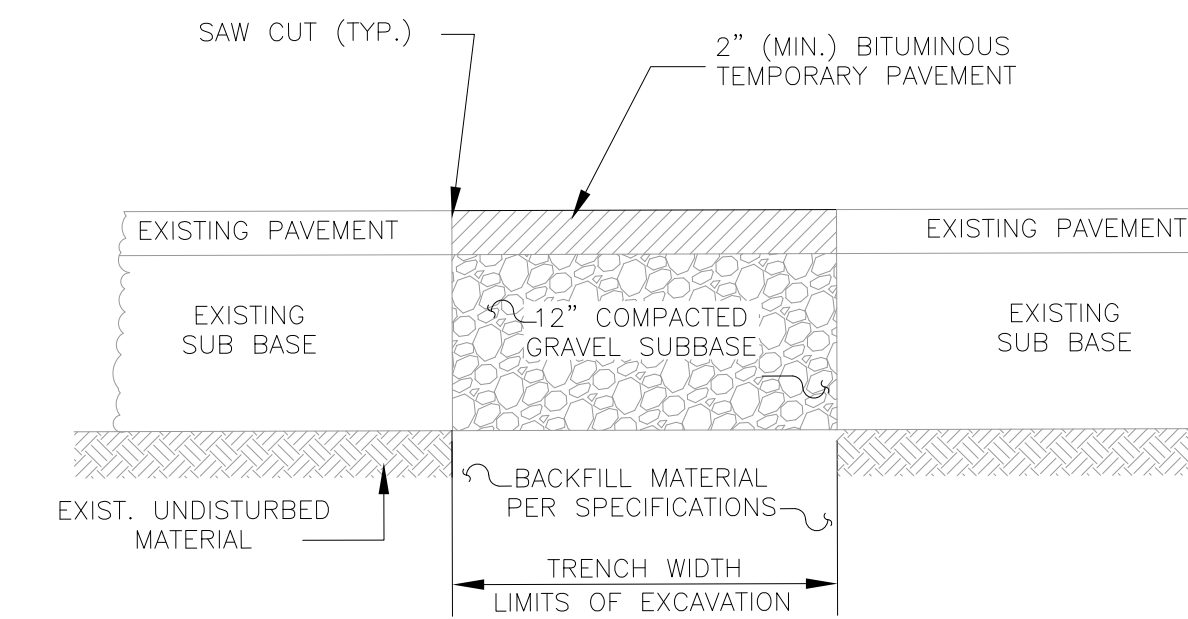

**TEMPORARY TRENCH PAVEMENT DETAIL**

NOT TO SCALE  
GENERAL PAVING NOTES:

- THE CONTRACTOR SHALL INSTALL TEMPORARY PAVEMENT ON A DAILY BASIS AS DIRECTED AND SHALL MAINTAIN TEMPORARY PAVEMENT FOR A MINIMUM OF 90 DAYS EXCEPT IF TEMPORARY PAVEMENT IS PLACED AFTER OCTOBER 15TH, THEN IT SHALL BE MAINTAINED UNTIL APRIL 15TH OF THE FOLLOWING YEAR UNLESS AUTHORIZED BY THE TOWN. TEMPORARY CENTERLINE OR FOG LINE PAVEMENT PAINT SHALL BE PLACED ON THE TEMPORARY PAVEMENT WHEREVER EXISTING PAINT IS DISTURBED DURING CONSTRUCTION.
- CONTRACTOR TO INSTALL TEMPORARY PAVEMENT AS DIRECTED BY ENGINEER. CONTRACTOR TO INSTALL PERMANENT TRENCH PAVEMENT OVERLAY PAVEMENT AS DIRECTED BY ENGINEER.
- PERMANENT PAVEMENT SHALL BE PLACED BETWEEN APRIL 15TH AND OCTOBER 15TH OF EACH CALENDAR YEAR UNLESS AUTHORIZED BY THE TOWN OUTSIDE THESE DATES.
- THE CONTRACTOR SHALL SAW CUT 12" OUTSIDE OF TRENCH EXCAVATION. TEMPORARY PAVEMENT SHALL BE REMOVED AND DISPOSED OF. THE GRAVEL SHALL BE FINE GRADED, EMULSION PLACED ON ALL JOINTS, AND PERMANENT PAVEMENT PLACED IN TWO COURSES.
- CONTRACTOR SHALL MATCH EXISTING ROADWAY GRADES AND EXISTING THICKNESS UNLESS OTHERWISE DIRECTED.
- REFER TO SPECIFICATION SECTION 02500 PAVING AND SURFACING FOR ADDITIONAL REQUIREMENTS.
- PERMANENT PAVEMENT DETAIL TO APPLY TO TRENCH PAVEMENT AND ROADWAY RECONSTRUCTION AND/OR PAVEMENT OUTSIDE OF TRENCH LIMITS.

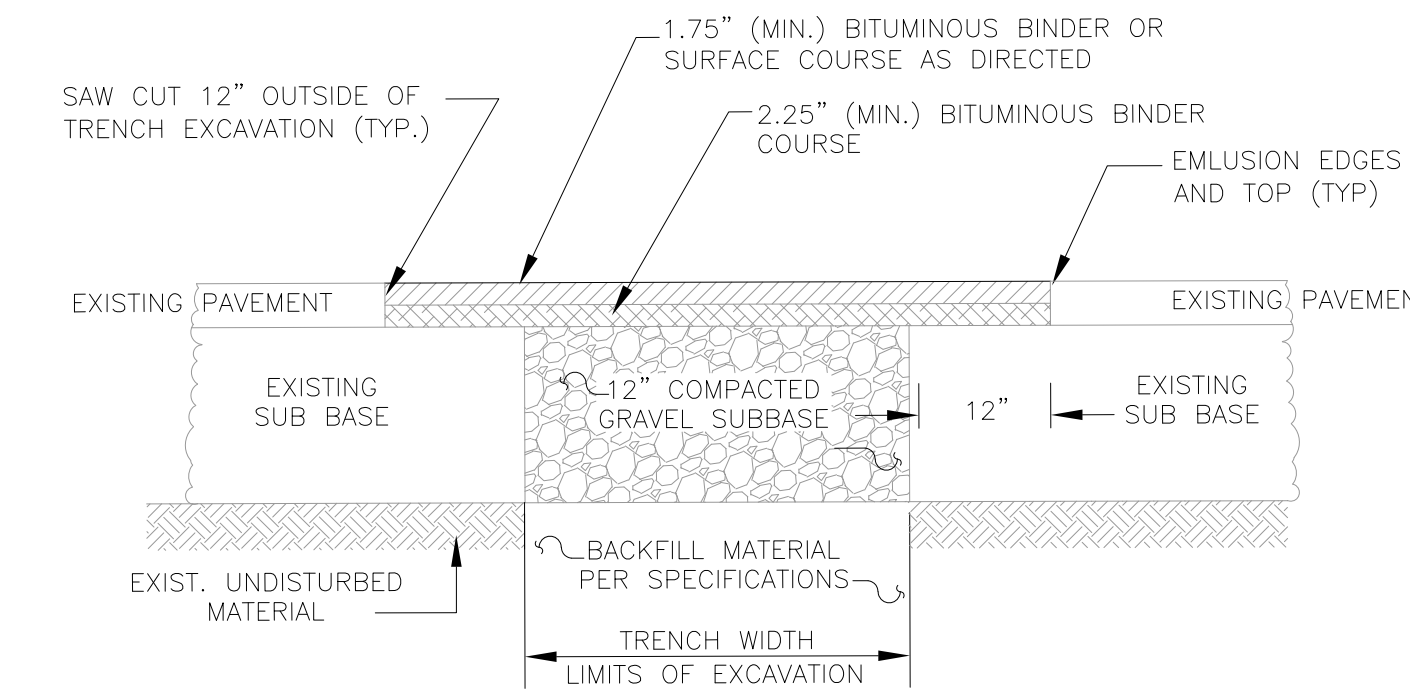

**PERMANENT TRENCH PAVEMENT DETAIL**

NOT TO SCALE

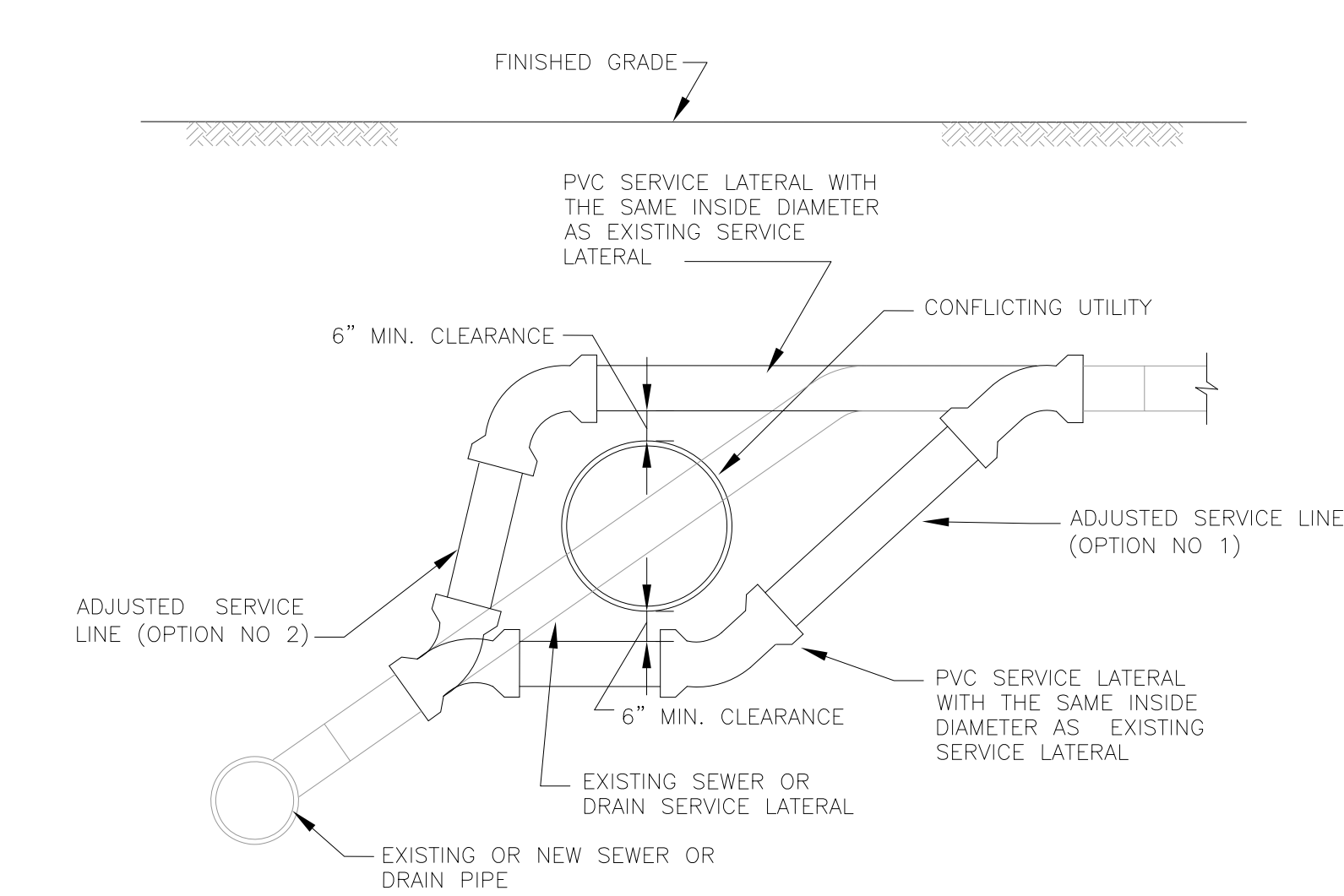

**SANITARY SEWER OR DRAIN SERVICE LATERAL RECONNECTION FOR CONFLICTS WITH OTHER UTILITY**

NOT TO SCALE

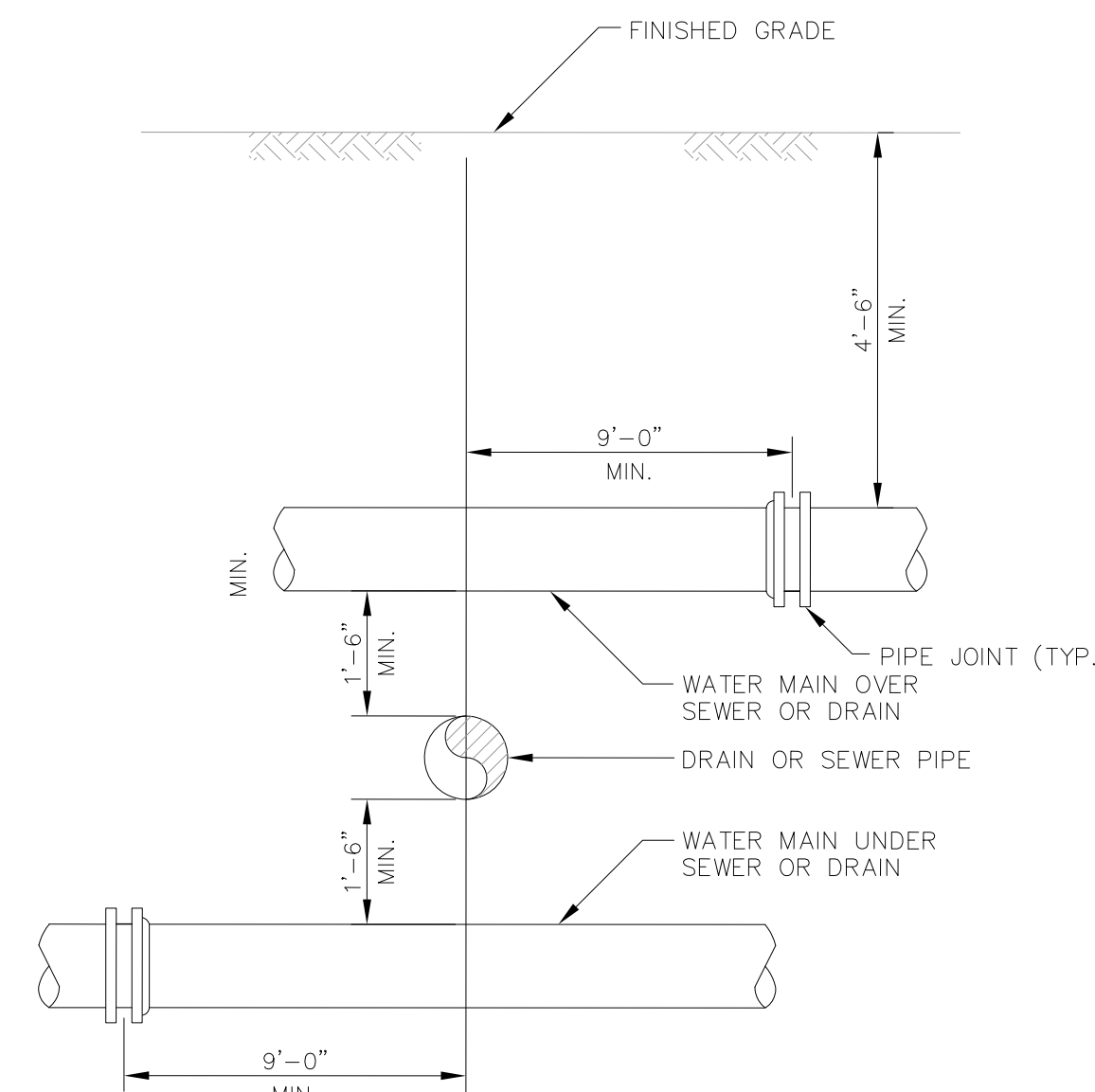

**WATER MAIN CROSSING WITH SEWER OR DRAIN**

NOT TO SCALE

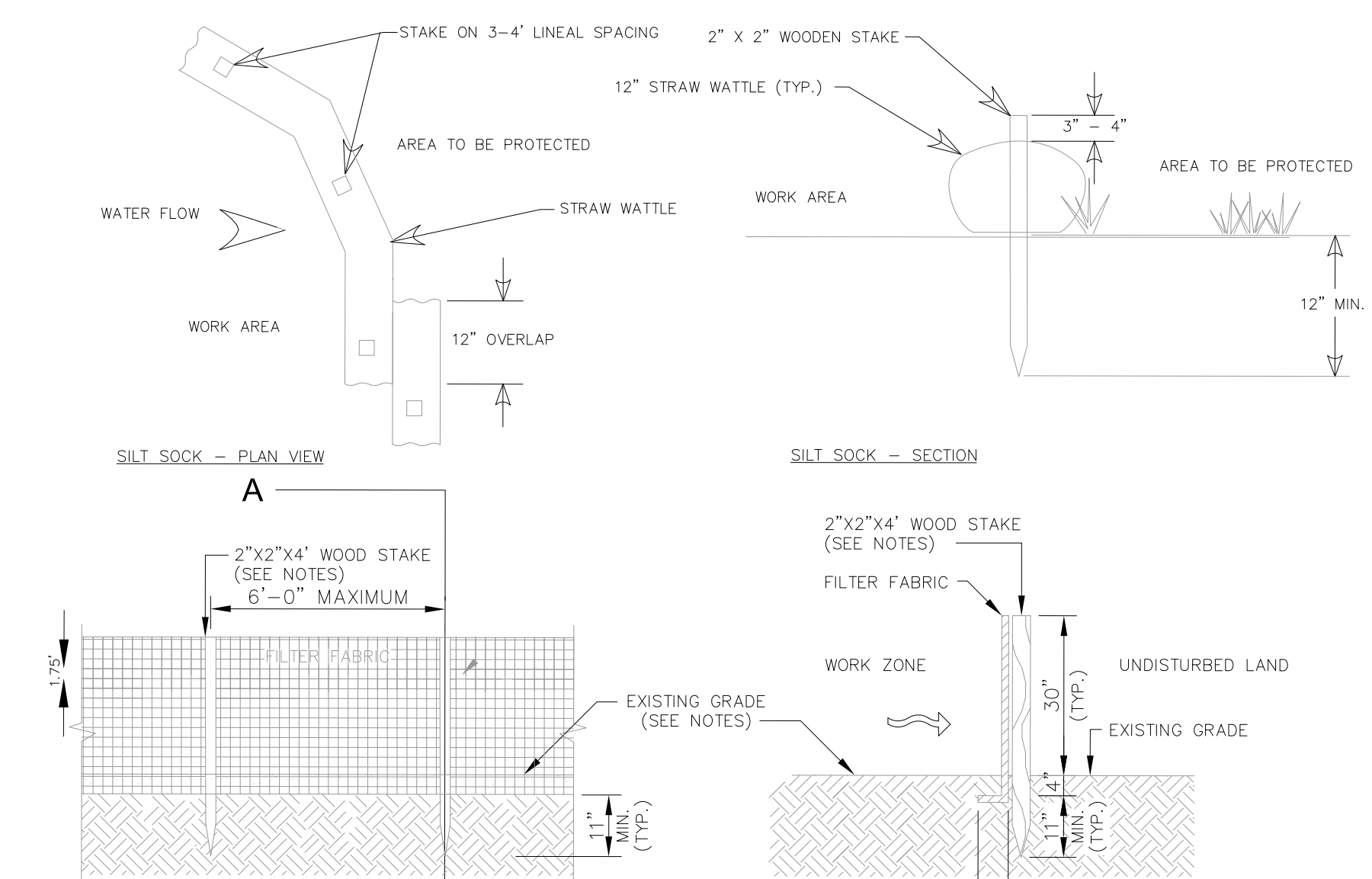

- NOTES:
- CONTRACTOR TO INSTALL 12-INCH STRAW WATTLES OR SILT FENCE AS DIRECTED AND APPROVED BY LOCAL CONSERVATION COMMISSION
  - FABRIC FOR FENCES TO BE UV RESISTANT POLYPROPYLENE WITH A MINIMUM WEIGHT OF 2.5 OZ/S.Y. TUBULAR BLACK POLYPROPYLENE FOR STRAW WATTLES SHALL BE PHOTO DEGRADABLE.
  - FABRIC TO BE ATTACHED TO STAKES WITH STAPLES.
  - HAY BALES, WHERE USED, SHALL BE SALT MARCH HAY AS APPROVED BY LOCAL CONSERVATION COMMISSION.
  - WHERE HAY BALES ARE USED, TRENCH A MINIMUM OF 4" INTO EXISTING GRADE.
  - A MINIMUM OF (2) WOODEN OR METAL STAKES PER HAY BALE. DRIVE STAKES A MINIMUM OF 12" INTO GROUND.
  - STRAW MATERIAL TO BE DISPERSED ON SITE OR HAULED OFFSITE AND DISPOSED AS DETERMINED BY THE ENGINEER.
  - CONTRACTOR TO INSTALL GEOTEXTILE (SILT SACK) IN ALL CATCH BASINS PRIOR TO EXCAVATION.
  - ALL CONSTRUCTION DEWATERING MUST BE TREATED WITH A FILTRATION DEVICE (DIRTBAG) AND/OR SEDIMENTATION TANK OR APPROVED TREATMENT DEVICE PRIOR TO DISCHARGE UPGRADIENT OF OTHER EROSION AND SEDIMENTATION DEVICES AND CONTROLS.
  - SEDIMENTATION AND FLOATABLE DEBRIS BARRIER TO BE SIZED AND MAINTAINED TO ACCOMMODATE VARIED WATER LEVELS IN ADJACENT WATER BODIES.

**EROSION AND SEDIMENTATION BARRIER**

NOT TO SCALE

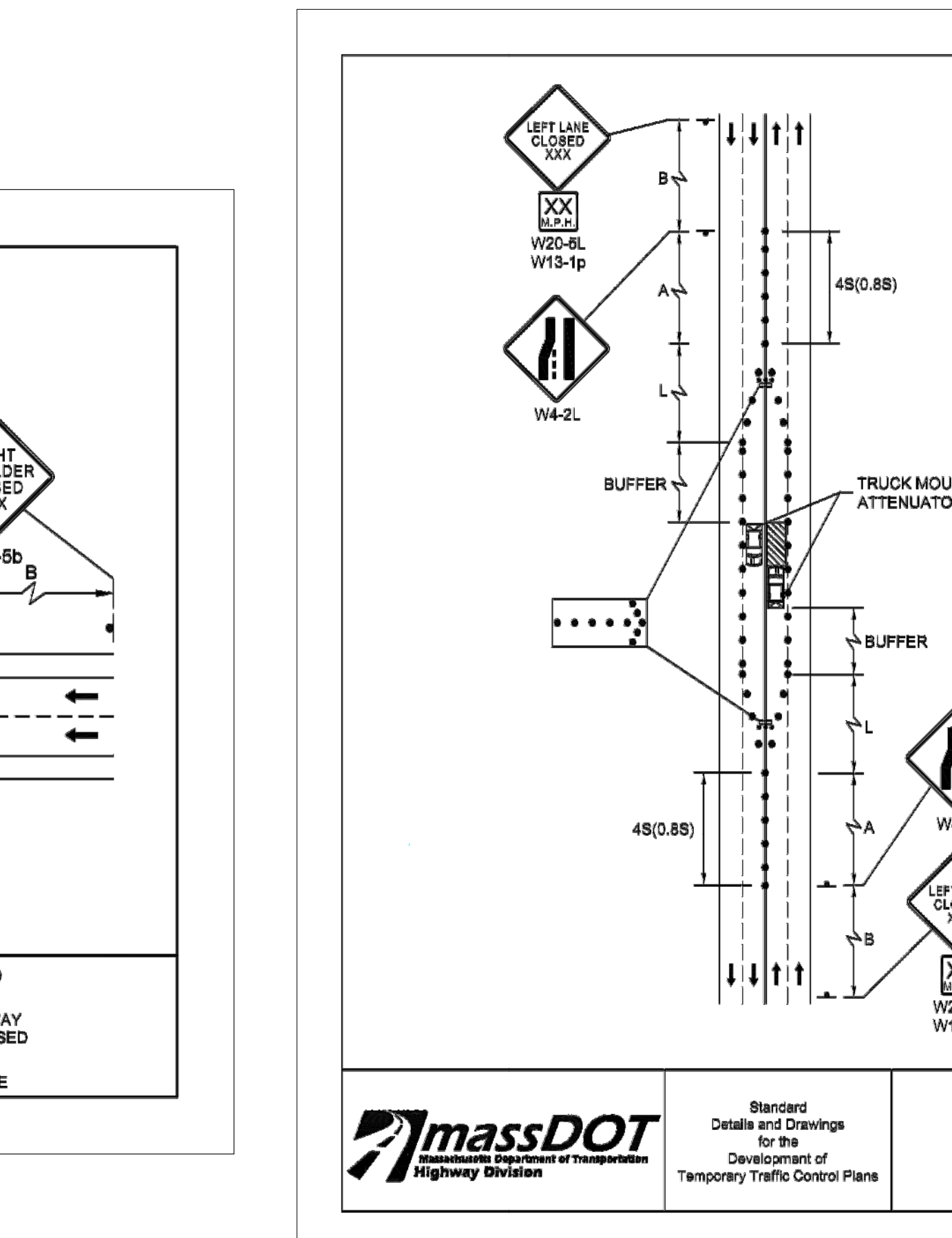
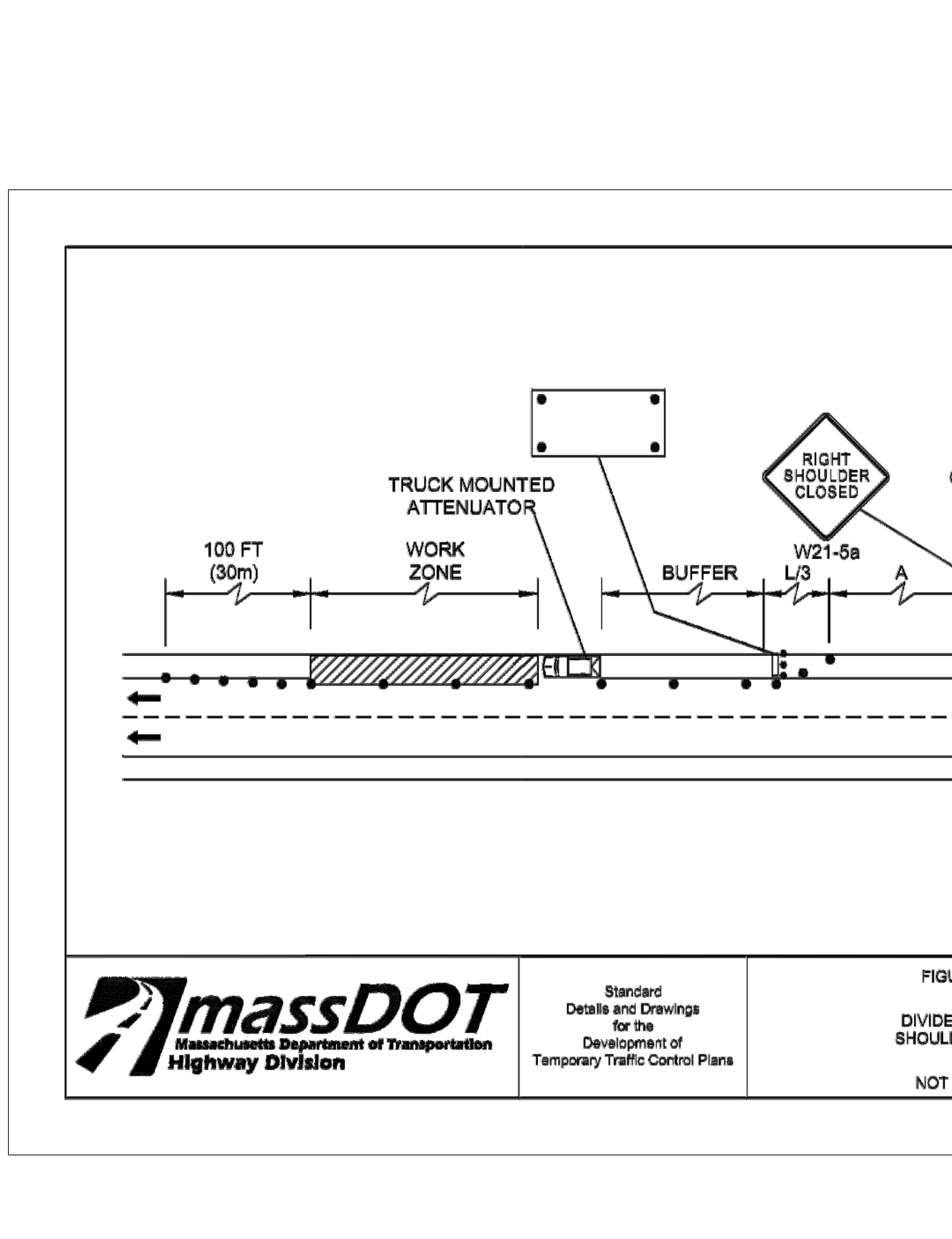
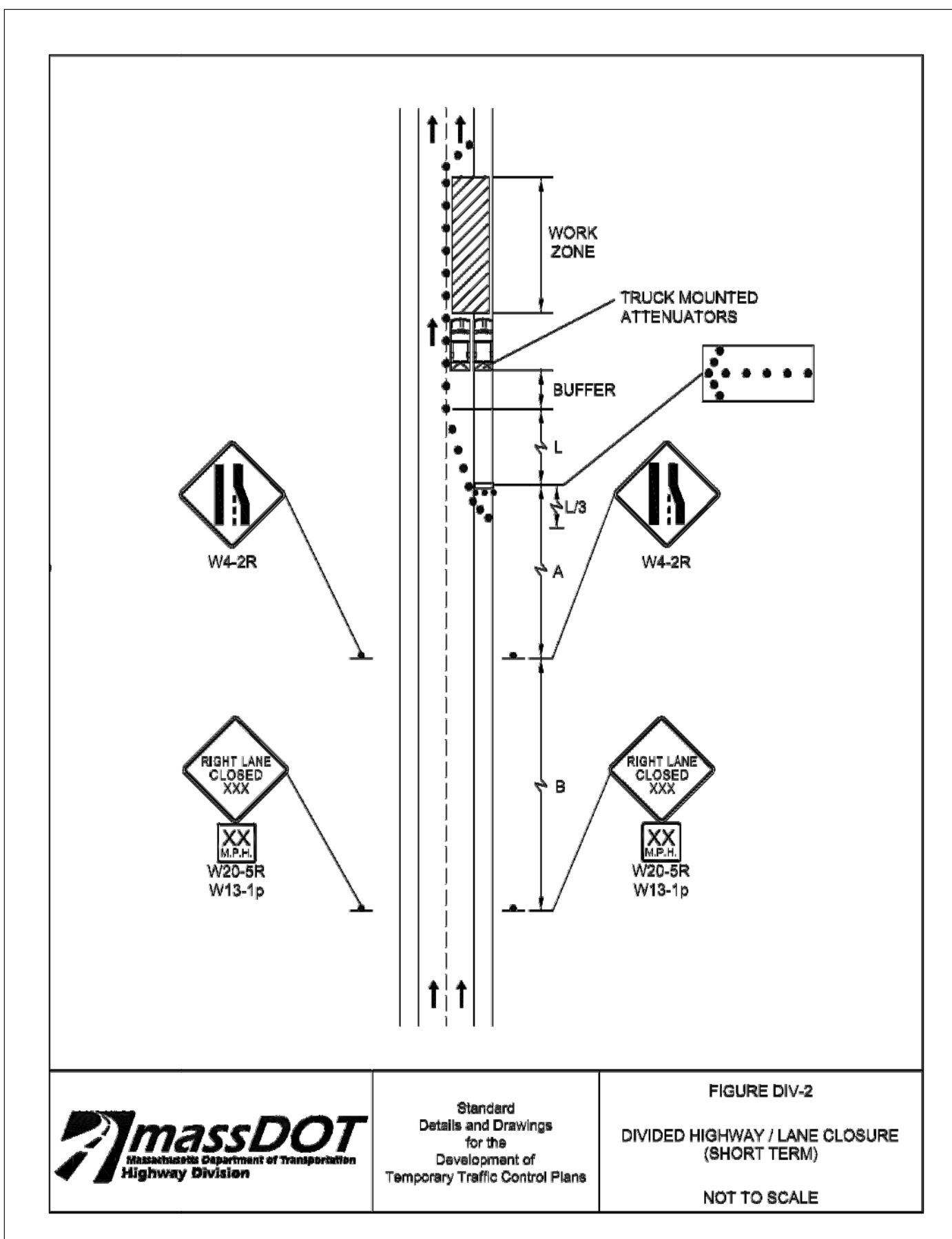
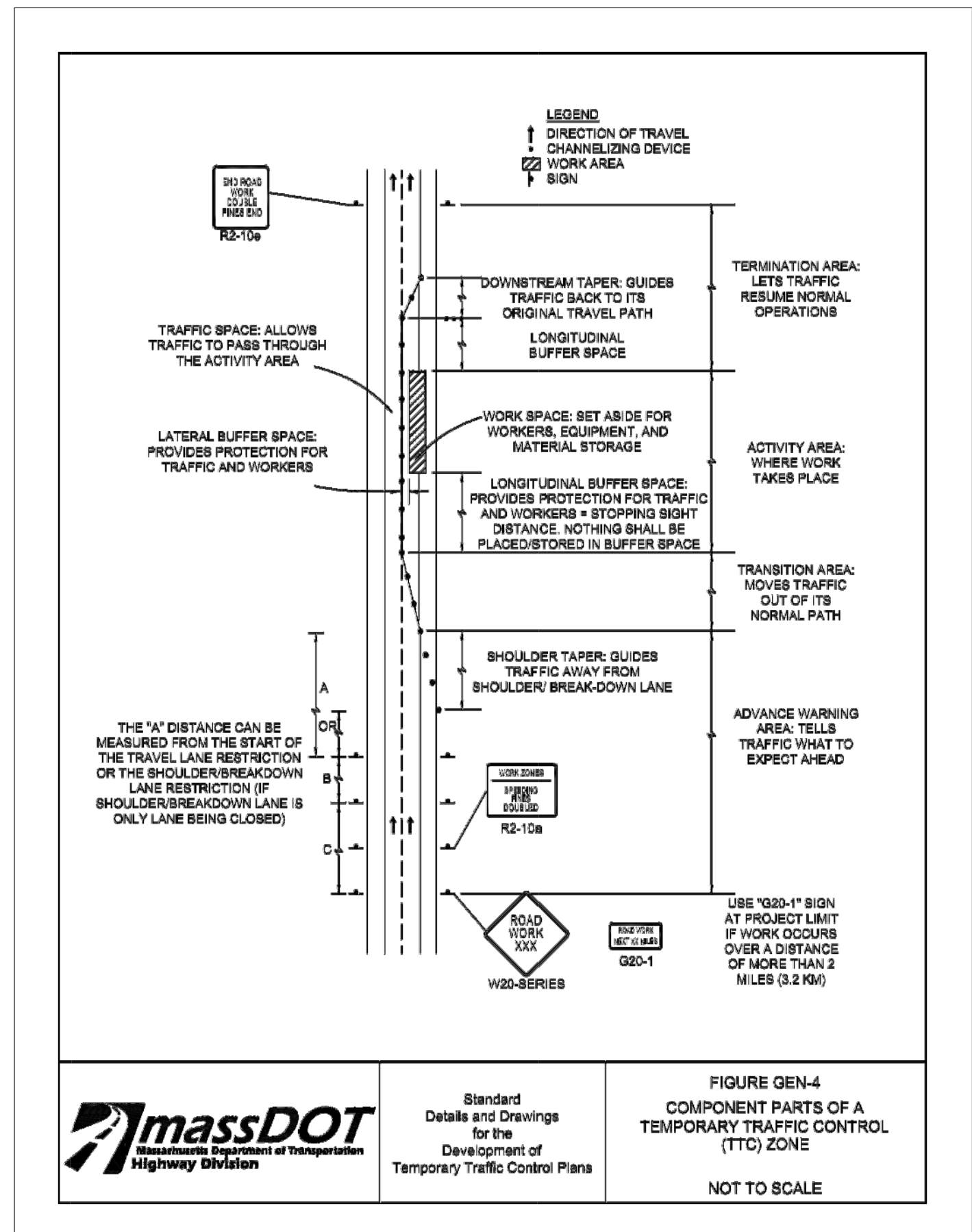
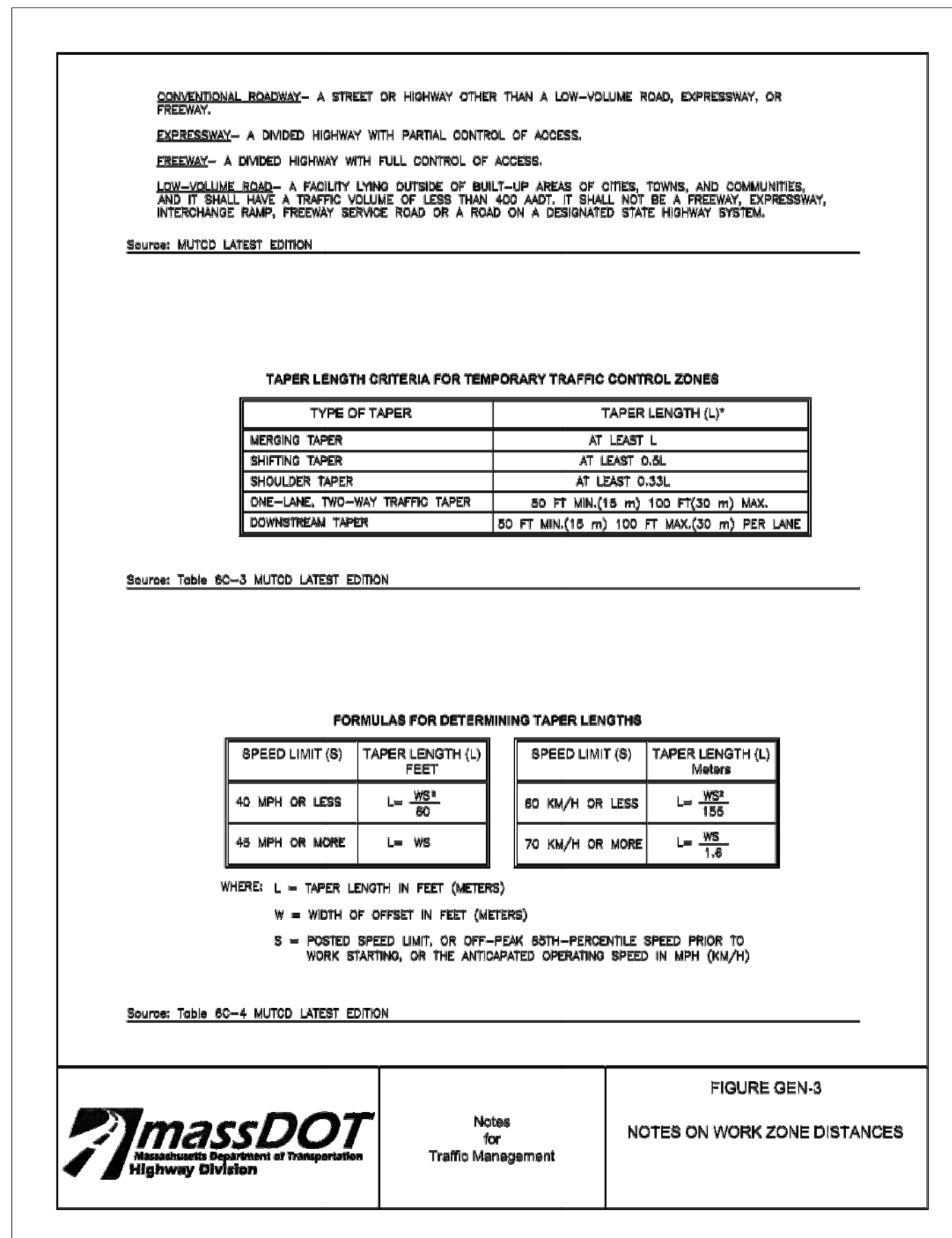
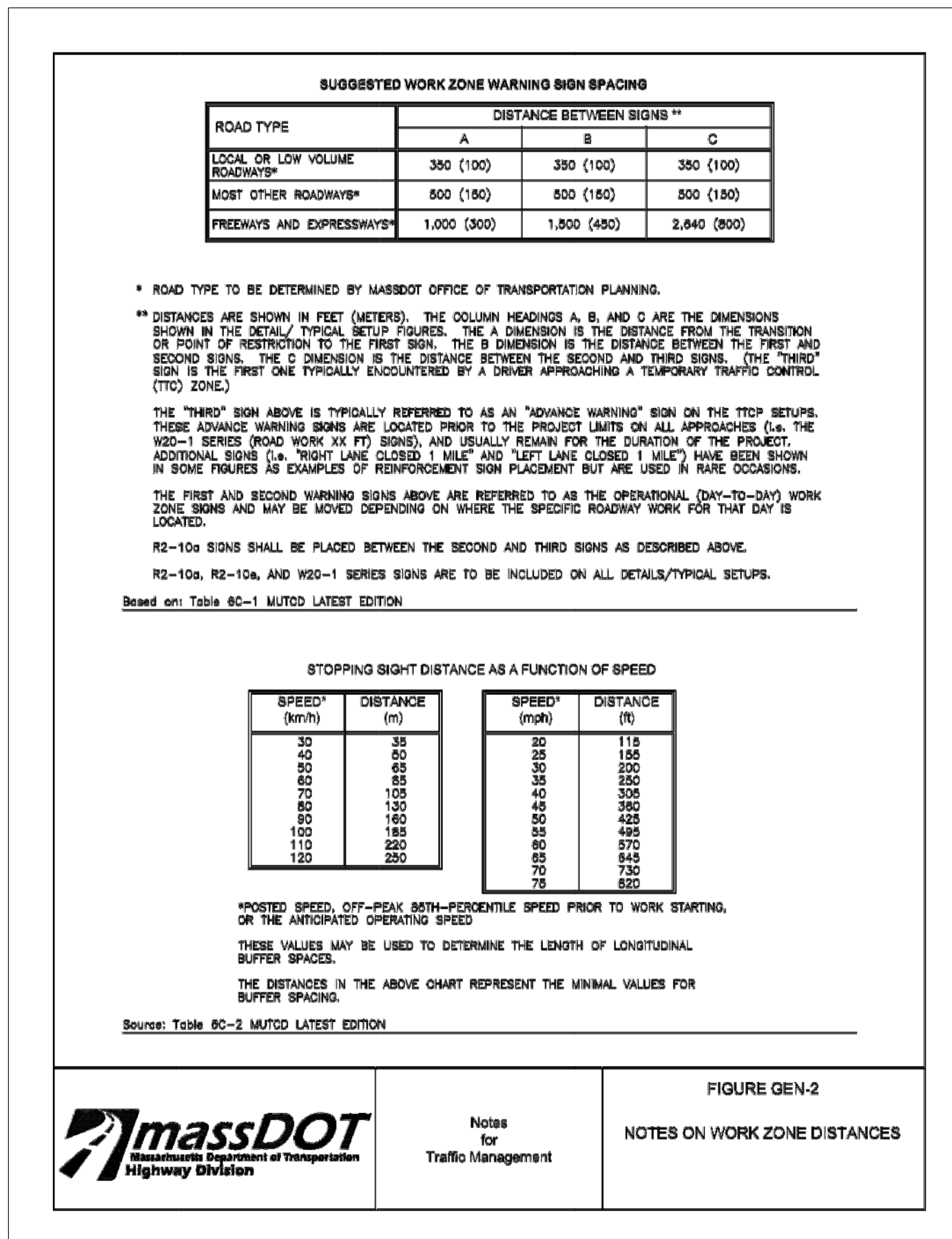
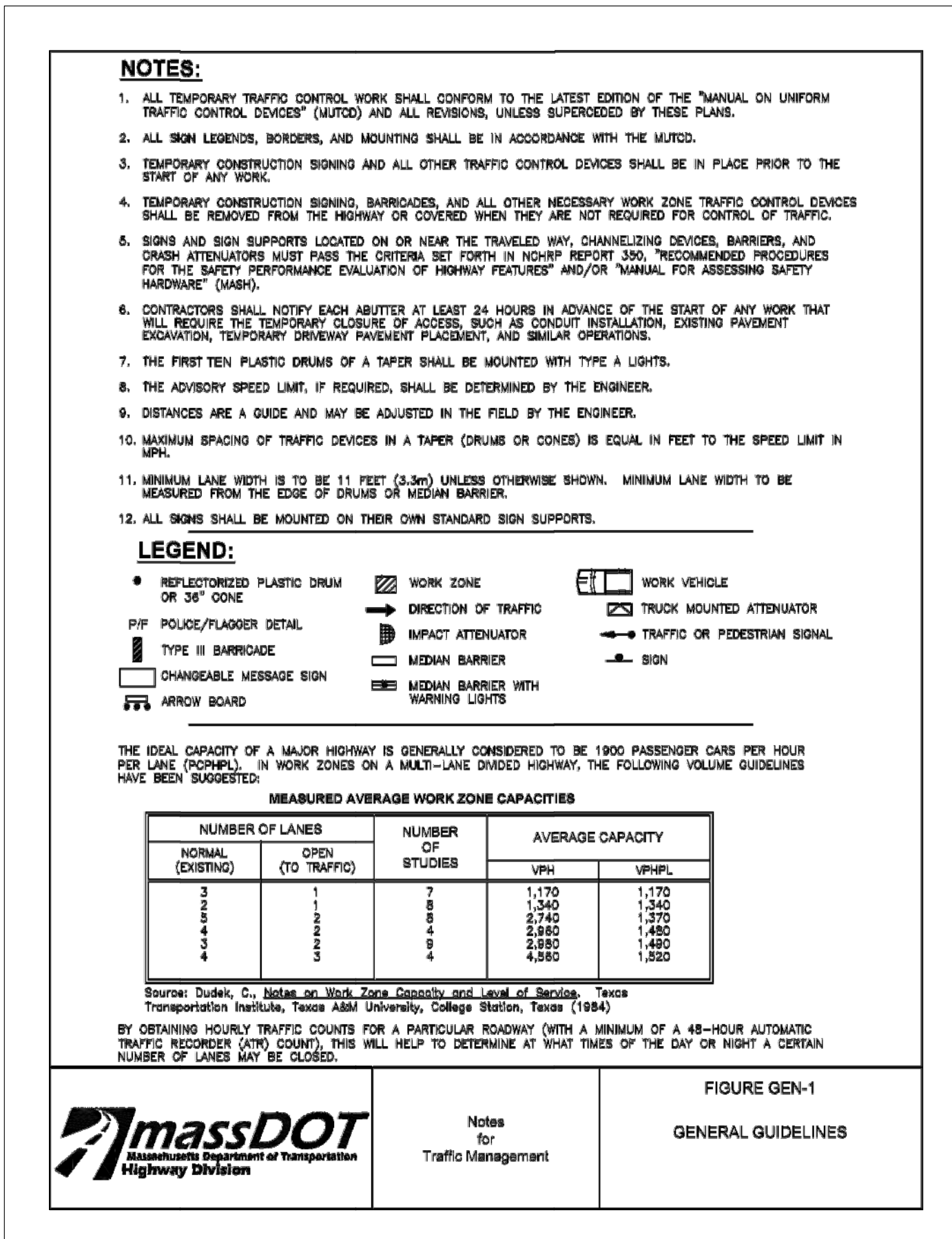

**NOTES**

- TRAFFIC CONTROL MEASURES SHALL INCLUDE USE OF POLICE DETAILS AS REQUIRED.
- TRAFFIC CONTROL SIGNAGE SHALL UTILIZE POLICE OFFICER AHEAD IN LIEU OF FLAGGER AHEAD.
- DISTANCES ARE A GUIDE AND MAY BE ADJUSTED IN THE FIELD BY THE ENGINEER OR POLICE DETAIL.
- ALL TEMPORARY WALKWAYS SHALL MEET ADA/AAIB GUIDELINES.
- ADA COMPLIANT PEDESTRIAN ACCESS SHALL BE MAINTAINED AT ALL TIMES AND SHALL INCLUDE ADDITIONAL SIGNAGE WHERE NEEDED TO DIRECT PEDESTRIAN TRAFFIC AROUND WORK ZONE.
- ALL WORK IN THE STATE HIGHWAY LAYOUT MUST BE COMPLETED BETWEEN THE HOURS OF 9:00 P.M. TO 5:00 A.M.

LEFT LANE CLOSURES SHALL USE W4-2L AND W20-5L SIGNS IN PLACE OF W44-2R AND W20-5R SIGNS RESPECTIVELY.

